

bus system with very short cycle times and an exact synchronisation at affordable prices, which gets more and more important in the industrial automation. EtherCAT can be used in a broad range of applications and is completely conformant to the current Ethernet standard.

The NAMC-ECAT is an EtherCAT (**E**thernet for **C**ontrol **A**utomation **T**echnology) slave interface in AMC (**A**dvanced **M**ezzanine **C**ard) form factor.

The NAMC-ECAT connects the two hemispheres of the real-time, high speed field bus EtherCAT and the flexible, scalable and powerful MicroTCA embedded architecture. The goal of the EtherCAT technology is to have a high speed real-time field

Using MicroTCA systems as dedicated slave nodes in an EtherCAT network adds a new dimension of intelligent, scalable and high performance network nodes to this industrial automation network.

The NAMC-ECAT and MicroTCA systems are dedicated to applications in the industrial automation, high energy physics, medical, defence and aerospace market.

# Technical Data

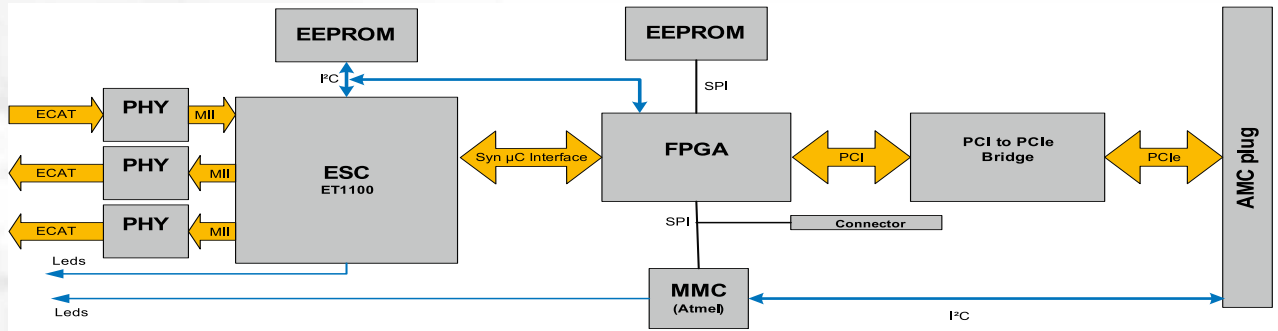

## Overview

The NAMC-ECAT is an EtherCAT slave interface in AMC (Advanced Mezzanine Card) form factor. It is available as single compact, mid or fullsize module.

With the NAMC-ECAT any embedded system based on the MicroTCA standard can be integrated as a slave node in an existing high performance, real time field bus system based on EtherCAT. The NAMC-ECAT offers three RJ45 connectors at its front panel to build networks with line, star and branch topology. Sensor and actor data transfer within the MicroTCA system is based on PCIeexpress.

## EtherCAT Description

The goal of the EtherCAT technology (Ethernet for Control Automation Technology) is to have a low price, high speed real-time field bus system with very short cycle times and an exact synchronisation, which gets more important in the industrial automation. EtherCAT can be used in a broad range of applications and is completely conform to the current Ethernet standard, but it has not the latency and the overhead issues of Ethernet.

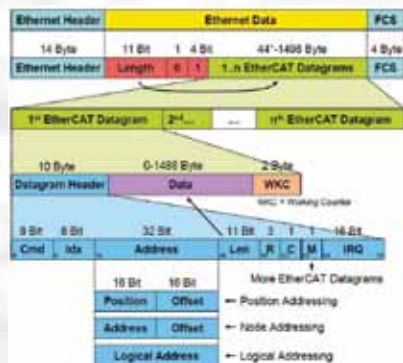

Reference: Beckhoff Automation GmbH

An EtherCAT network has an EtherCAT Master, which controls the network of EtherCAT slave devices. Up to 65535 EtherCAT slaves can be integrated with a distance of up to 100 m to each other summing up to unreached distances ( $n * 100$  m) for the whole network. The topology of the field bus network can be line, star and branch.



## EtherCAT Master

To use a MicroTCA system as EtherCAT master only a standard CPU AMC module running the Master EtherCAT software and a standard Ethernet are needed.

## EtherCAT Slave

To use a MicroTCA system as EtherCAT slave a special AMC module is needed, which adds and drops information on the fly in real time into the EtherCAT bit stream. This is the function of the NAMC-ECAT.

MicroTCA systems as slave devices of an EtherCAT network can be used for image and sensor preprocessing or for complex control application as e.g. for robot. In addition EtherCAT allows also the transfer of standard Ethernet packets. Therefore all the new features of remote control and management functions of MicroTCA systems can be used over the same cable.

## NAMC-ECAT Details

Key component of the EtherCAT slave card NAMC-ECAT is the ESC (EtherCAT Slave Controller) as interface between the EtherCAT bus and the user application. As ESC the EtherCAT-ASIC ET1100 from Beckhoff is used.

The ESC ET1100 has an 8 kByte RAM to simultaneously exchange data between the EtherCAT network and the Process Data Interface (PDI). The PDI interface is directly accessible from other AMC modules via the backplane PCIe interface.

Simultaneous updates of the registers from the EtherCAT interface and the PDI interface side are implemented.

The EtherCAT physical connection is realised with three ports at the front panel supporting all defined topologies of an EtherCAT network. Each port has an auto forwarder and loop back function, which detect a broken cable and if a second Ethernet cable is used allow a redundant configuration and continuation of data transfer.

## Technical Data NAMC-ECAT

### AMC Formfactor and Compliance

single compact, mid or full size  
AMC.0 R2.0

### PCIe Interface and Compliance

1 lane to Port 4  
PICMG AMC.1 R1.0

### IPMI and Compliance

IPMI V2.0

### EtherCAT System Controller

ESC ET1100 EtherCAT-ASIC  
3 RJ45 at front panel

### Memory

8 kByte

### Indicator LEDs

1 blue LED  
2 status LEDs  
6 link status LEDs

### Host Operating System Support

OK-1, LINUX  
VxWorks (on request)

### Power Consumption

3.3V MP 0.1A (max.)  
12V 0.3 A (typ.)

### Environmental

#### Temperature (operating):

0°C to +60°C with forced air cooling,

#### Temperature (storage):

-40°C to +85°C

#### Relative Humidity:

10% to 90% at +55°C (non-condensing)

### Applications

- Industrial Automation
- Aerospace and Defence
- High Energy Physics
- Medical

