

## NAMC-STM1 NAMC-STM4

The NAMC-STM1 and NAMC-STM4 are telecommunications interface boards in **AMC (Advanced Mezzanine Card)** form factor for use with an ATCA or uTCA system. The NAMC-STM1 and NAMC-STM4 are targeted at telecom applications dealing with **SDH (Synchronous Digital Hierarchy)**, such as SS7, ISDN or 3G/3.5G mobile applications in optical OC-3/STM-1 or OC-12/STM-4 and SONET environments.

Being equipped with an add/drop multiplexer/demultiplexer chipset both the NAMC-STM1 and the NAMC-STM4 are ideal single board platforms to interface between the frame oriented STM-1/4 SDH based networks and classic **TDM (Time Division Multiplex)** standards i.e. as E1/T1/J1 or E3/T1/J3. Both boards provide I-TDM functionality on either AMC ports 0 or 1.

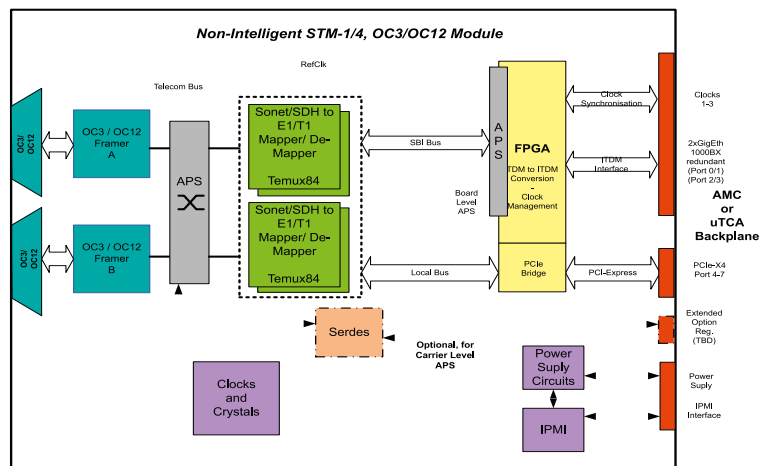

## Overview and Purpose

Both the NAMC-STM1 and the NAMC-STM4 are telecommunications interface boards in AMC (Advanced Mezzanine Card) form factor. The NAMC-STM1/4 is targeted at telecom applications dealing with Synchronous Digital Hierarchy (SDH), such as SS7, ISDN or 3G/3.5G mobile applications in optical OC-12/STM-4 and SONET environments.

Being equipped with an add/drop multiplexer/demultiplexer chipset the NAMC-STM1/4 is an ideal single board platform to interface between the frame oriented STM-4/SDH networks and classic TDM (Time Division Multiplex) standards as E1/T1/J1 or E3/T3/J3. Possible applications are i.e. add/drop or terminal multiplexers.

## Optical Interface

The optical 155Mbps OC3/STM1 line interface of the NAMC-STM1 and the 622Mbps OC-12/STM-4 line interface of the NAMC-STM4 are both available on standard OC-3/OC-12 SDH STM-1/STM-4 connectors at front panel.

## VT/TU Access

Both the OC-3/STM1 and the OC-12/STM-4 framers are connected to an add/drop multiplexer/demultiplexer chipset. Since the chipset does the complete SDH pointer processing it is capable of accessing VT/TU tributary unit groups within the VC3, VC4 and VC4-4c virtual containers and thus to extract/insert any of the 84 T1/J1 or 63 E1 streams (NAMC-STM-1) or 4\*84 T1/J1 or 4\*63 E1 streams (NAMC-STM4) including the respective clocking information contained in a single STM-1 or STM-4 SDH frame.

Supported mappings are VT1.5/VT-2 or TU-11/TU-12 to VC3/VC4/VC4-4c or STM-4/STM-4c. The chipset supports the M13 and G.747 multiplexing.

## T1/J1/E1 Access

The multiplexer/demultiplexer chipset on the NAMC-STM1 includes 84 T1/J1 or 63 framers while the one on the NAMC-STM4 includes 4x84 T1/J1 framers or 4x63 E1 framers. Each framer has its individual Rx/Tx, CLK and SYNC signals. For T1 the framing standards SF, SLC-96 and ESF, for E1 G.704 and G.706 (CRC-4 multiframe), for J1 the TTC JT-G.704 as well CRC-6 calculation are supported. The chip also provides full jitter attenuation.

## TDM and I-TDM Interface

The E1/T1/J1 framer interfaces to the on-board timeslot interchanger (TSI) chipset. The TSI as well as the TDM-to-I-TDM bridge are incorporated in an onboard FPGA. The TSI allows flexible routing as well as multicasting of 64kbps timeslots between the various E1/T1/J1 streams. The TDM-to-I-TDM bridge converts the TDM oriented bit stream into Ethernet packets and vice versa. The Ethernet packets are sent and received via either the AMC ports 0 or 1 (selectable) 1000BaseT-BX Ethernet interface (Fabric A).

In addition to the I-TDM interface, as a breaking-through feature of the NAMC-STM4, the TSI offers an optional 32Mhz clocked H.110-like TDM backplane interface on the AMC extended connector.

## IPMI and Compliance

PICMG AMC.0 R1.0  
PICMG 2.9 R1.0

## I-TDM and Compliance

GigETh (Fabric A)  
at common options region  
PICMG SFP.1 R1.0

## TDM (option)

H.110 like 32MHz clocked TDM interface at extended option region

## Networking

One OC-3 SDH/STM-1 (NAMC-STM1) or OC-12 SDH/STM-4 (NAMC-STM4) optical fibre interface on standard connector at front panel (SC duplex single or multi mode transceiver), one GigETh at common options region (port 0 or port 1, selectable)

## PCIe Interface and Compliance

X4 PCIe interface (optional)  
PICMG AMC.1 R1.0

## Indicator LEDs

4 software programmable LEDs  
at front panel

## Operating System Support

(host drivers)  
OK-1, VxWorks, LINUX

## Power Consumption

3.3V, 12V, 20W typ.

## Environmental

Temperature (operating):  
0°C to +60°C with forced air cooling  
Temperature (storage):  
-40°C to +85°C  
Relative Humidity:  
10% to 90% at +55°C (non-condensing)

## Applications

- high density multiplexers, multi-service switches, edge routers and digital modems
- Frame Relay switches and access devices
- SONET/SDH add drop and terminal multiplexers
- optical access equipment
- digital access cross-connect systems

