

# NAMC-QorIQ-P40 NAMC-QorIQ-P50



The **NAMC-QorIQ-P40** and the **NAMC-QorIQ-P50** are the market's most powerful single-width mid- or full-size AdvancedMC™ (AMC) processor boards designed around the high-performance Freescale™ octal core PowerPC cores QorIQ® P4080 / dual core P5020 and Xilinx® Virtex®-6 FPGA.

Key features are:

- latest Freescale QorIQ P4080 processor with eight cores at up to 1.5 GHz
- latest Freescale QorIQ P5020 dual core processor at up to 2.2 GHz
- Xilinx Virtex-6 FPGA
- memory
  - 2-8 GB DDR3 SDRAM at 1.3GHz
  - 2 GB of NAND Flash
- interfaces at front panel
  - 1 x 10/100/1000-BaseT Ethernet
  - 10 GBit (XAUI) SFP+ Ethernet
  - USB Console Interface
- backplane connections
  - 2 x GbE to AMC Ports 0/1
  - 2 x SATA to AMC Ports 2/3
- a choice of
  - PCIe x4, SRIO x4 or XAUIx4 at AMC ports 4-7 or 8-11
- I-TDM interface
- optional: H.110 like backplane TSI bus

## NAMC-QorIQ-P40 /-P50

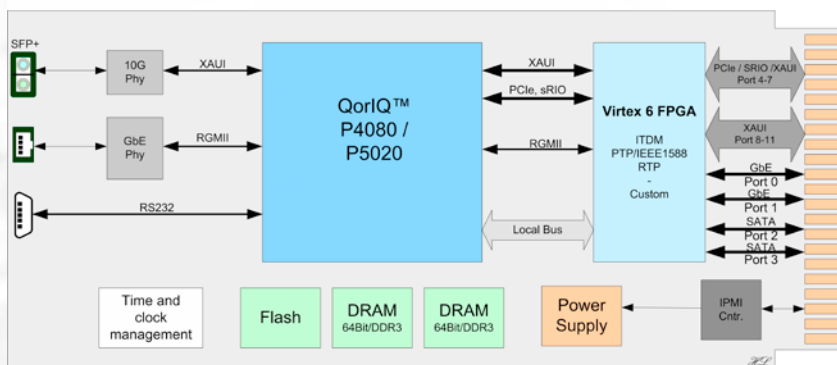

The **NAMC-QorIQ-P40** and the **NAMC-QorIQ-P50** are powerful packet processing engines in AMC form factor based on Freescale's QorIQ P4080/P5020 communications processors, designed for today's packet oriented telecom applications such as LTE or VoIP.

### P4080 / P5020

The P4080 / P5020 are multi-core packet processors offering eight e500mc PowerPC cores at up to 1.5 GHz or dual 64-bit e5500 cores at up to 2.2 GHz. They provide security and pattern match engines, sophisticated buffer and queue management, and additionally various high speed serial data links. Thus, the boards are ideally suited for applications in ATCA and MTCA environments. The QorIQ P4080 is designed for combined control and dataplane processing enabling high-performance Layer2-7 processing.

The board can optionally be equipped with the P5020 processor providing real 64 Bit dual core processing power based on the e5500 core. The rich feature list of the P4080/ P5020 CPU turns the NAMC-QorIQ into a state-of-the-art packet processing board.

The P4080/P5020 packet processor is accompanied by a set of supporting hardware blocks for time keeping/tracking as well as for external protocol processing/conversion and acceleration.

### The best of two worlds

The powerful QorIQ processor in combination with the most advanced Virtex-6 FPGA architecture results in an unrivalled power engine for data and packet processing as well as protocol acceleration. Providing I-TDM support by default, a major part of the FPGA is available for customer use.

### Real time clock/PLL

The board is equipped with an on-board Real Time Clock and precision oscillator to support time keeping and time tracking for protocols like RTP (Real Time Protocol) or PTP (Precision Time Protocol, IEEE 1588).

The low jitter PLL allows telecom clocks to be derived from on-board sources and to be provided to the system by the MTCA clock distribution network.

### Load Indicators

Each of the two/eight PowerPC cores has its own load indicator LED at the front panel. The load indicators provide a visual feedback of the current load balancing between the individual CPU cores.

### Applications

Due to the unique combination of the powerful and feature-rich packet processor and the user accessible FPGA, the NAMC-QorIQ is ideally suited to any voice/data application with requirements like deep packet inspection, encryption, protocol conversion or Layer 2-7 routing. The NAMC-QorIQ is the optimal choice for applications like multi-service switches, edge routers, radio network controllers (RNCs), VoIP/VoP gateways and routers as well as mobile network equipment.

## Technical Details

### Form Factor

AMC: Full Size, Mid Size

### CPU Core

QorIQ P4080/P5020 - latest packet processor technology from Freescale

- 8 x e500mc PowerPC Cores @ 1.5 GHz (P4080) or 2 x e5500 PowerPC Cores @ 2.0 GHz (P5020)
- Security Engine
- Pattern Match Engine
- Queue and Buffer Managers
- Dual 64 bit Memory interfaces
- 18 x Serdes (2 x XAUI, 3 x PCIe, 2 x SRIO, 8 x SGMII)

### Performance (P4080)

- IP v4 forwarding : up to 20 Gbps or 18 Mpps (packets per sec)
- IPsec Decap/Encap: up to 5 Mpps

### Memory

- 2 banks of 64 bit DDR3 DRAM, 1 or 2 GByte each
- Flash Memory 1GByte

### Backplane Interfaces

- XAUI, SRIO, PCIe at AMC Fat Pipe region (ports 4-7) or (ports 8-11)
- dual GbE (ports 0+1)
- dual SATA (ports 2+3)

### Front Panel Interfaces

XAUI at SFP+, GbE, USB

### FPGA

- Xilinx Virtex 6, supported devices: XC6VLX130T, XC6VLX195T, XC6VLX240T, XC6VLX365T

IP cores available for:

- ITDM support
- IEEE1588/RTP timestamp insertion / synchronization
- PTP protocol acceleration

Almost completely available for customer usage.

### LEDs

Standard AMC LEDs for hotswap and system health

- 2/8 Load Indicator LEDs for CPU Cores
- 4 Leds indicating GbE and SPF+ line states

### Operating Systems

Linux, QNX, OK1-M, OSE, VxWorks

### Power Consumption

The NAMC-QorIQ is designed to meet the following standards/qualifications: MTCA.0 R1.0 & R2.0, AMC.0 R2.0, AMC.1, AMC.2, AMC.4, IMPI V1.5 & V2.0 EN60950, UL1950, RoHS

