

NAT-MCH Gen 3

Technical Datasheet

The NAT-MCH is the most advanced MicroTCA Carrier hub design in the market and covers all aspects of management, high speed interconnectivity and clock distribution within today's MicroTCA systems.

The NAT-MCH is a multi-tongue design consisting out of a base module for management and Fabric A (GbE) connectivity, a clock module and hub modules for high speed fat pipe links supporting PCIe, XAUI or SRIO.

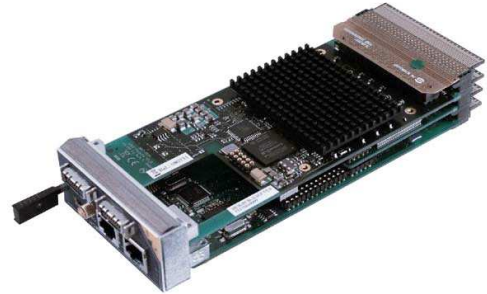

General:	
Form Factor:	Full Size, Mid Size, Compact Size ^(*)
Variants and Options:	MCH-Base – Base module for management and Fabric A (GbE) Switching MCH-BaseLC – Low Cost Variant Clock – Clock Module providing Telecom and Fabric Clocks Switching: Hub modules for PCIe, SRIO and XAUI
Faceplate and Uplinks:	Bicolor LED Indicators for each AMC, Cooling Unit and Power Module Dual GbE uplink for Fabric A Dual Clock input/output Fat Pipe Uplinks for SRIO and XAUI , SFP+ or CX4 connector USB/RS232 Console Interface (CLI)
Configuration Interfaces:	WEB Console Interface (USB/RS232) (CLI) Script language support for configuration of Ethernet switch and clock module IPMI via RMCP
Management Software:	NATview – free Graphical User Interface (open)HPI ipmitool ENEHA Element HA middleware
Power consumption:	7W at 12V Payload Power (Base module only) + 3W for Clock Module if equipped + 10-29W for Hub Module if equipped 100 mA at 3.3V Management Power
Standard Compliance:	The NAT-MCH is designed to meet the following standards and qualifications: MTCA.0 R1.0 & R2.0 ^(*) , AMC.0 R2.0, AMC.1, AMC.2, AMC.4, IMPI V1.5 & V2.0 EN60950, UL1950, RoHS

(*) available Q1 2010

(*) in preparation

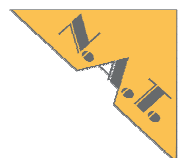

NAT-MCH Base Module

Tongue 1

The MCH Base module provides management functionality for 6 or 12 AMC modules, 2 cooling units and up to 4 power modules. The onboard Shelf Manager allows stand alone operation of MicroTCA systems.

The RMCP compliant management interface enables access for external Shelf- and System Managers.

The Base module contains a non-blocking GbE switch for fabric A with a dual uplink connector available at the faceplate.

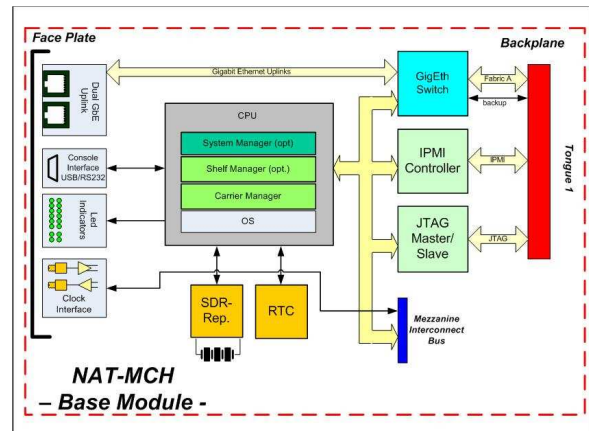

Base Module:	
Form Factor:	Full Size, Mid Size, Compact Size ^(*)
IPMI Management:	Support for 12 AMCs, 2 CUs 4 PMs Onboard Shelf Manager RMCP interface for external Shelf and System Manager Full redundancy and load sharing support E-Keying Power fail save Sensor Data Repository (SDR)
GbE Switch Fabric A:	Non-blocking, low latency, managed Layer 2 Switch Dual Uplink with port trunking Onboard firmware support for: 802.1Q VLAN, 802.1P QoS, 802.1X Port based Security, Jumbo Frames, Link Aggregation
LED Indicators:	Bicolor status indicator LEDs for each AMC, Power Module and Cooling Unit ^(*) Standard AMC LEDs indicating Hot Swap, failure and primary / secondary MCH
JTAG:	JTAG Master / Slave support ^(*)
Configuration Interfaces:	WEB Console Interface CLI (USB/RS232) Script language support for Ethernet switch and Clock module IPMI via RMCP
Standard Compliance:	The NAT-MCH is designed to meet the following standards and qualifications: MTCA.0 R1.0 & R2.0 ^(*) , AMC.0 R2.0, IMPI V1.5 & V2.0 EN60950, UL1950, RoHS
Power consumption:	7W
Configuration / Order Codes:	MCH-Base 6 – support for 6 AMC MCH-Base12 – support for 12AMC MCH-Base6LC – Low cost variant for up to 6 AMC slots MCH-Base12LC- Low cost variant for up to 12 AMC slots

(*1) available Q1 2010
(*2) not equipped on LC version
(*3) in preparation

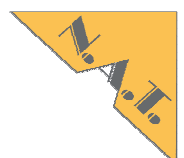

NAT-MCH Clock Module

Tongue 2

The **MCH Clock** module is the central clock distribution unit within a MicroTCA system. It receives and distributes clock signals between the AMC modules and the outside world. It supports Telecom clocking as well as Fabric clocks. The clock input can be sourced from either one of the AMC modules or the faceplate clock connectors. The onboard PLL enables re-synchronization and provides a highly accurate output signal.

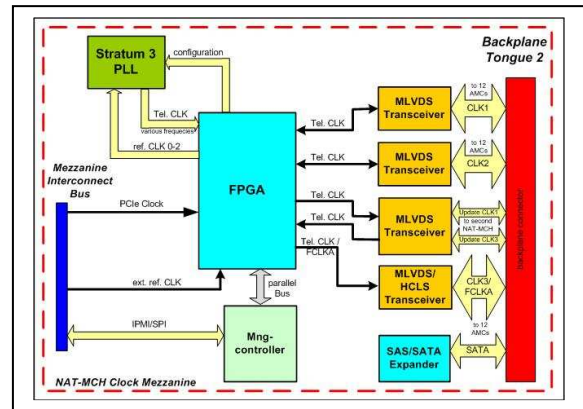

Clock Mezzanine:	
AMC Clock Lane Support:	CLK1: Input or Output, software selectable CLK2: Input CLK3/FCLK: Output
Faceplate Clock Input:	Dual SMA Connector, Software configuration of dual input dual output or mixed input/output Input Frequency: 1Hz – 32 MHz Input Signal: 200mV – 3V, single ended, 50 Ohm termination
PLL:	Accuracy: Stratum 3, Stratum 3e (Option TCOCXO) Supported Frequencies: Sonet/SDH: 6.48 MHz, Nx19.44 MHz, Nx51.84MHz Ethernet: 2.5, 25, 125, 156.25 MHz PDH: NxDS1, Nx1E1, NxDS2, DS3, E3 GPS 10 MHz Any Multiple of 2KHz up to 131.072MHz Any Multiple of 8KHz up to 155.52 MHz Jitter Performance: 1ns RMS
Configuration:	Clock E-Keying Script language IPMI
Power consumption:	3W at 12V
Standard Compliance:	The NAT-MCH is designed to meet the following standards and qualifications: MTCA.0 R1.0 & R2.0 ⁽³⁾ , AMC.0 R2.0, IMPI V1.5 & V2.0 EN60950, UL1950, RoHS
Options / Order Codes:	- TCTCXO – standard oscillator for Spectrum 3 compliance - TCOCXO – oven heated oscillator for Stratum 3e compliance - SSCH – PCIe 100 MHz FCLK-A – HCSL signaling

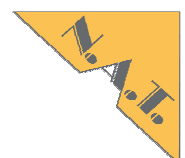

NAT-MCH HUB Modules

Tongue 3+4

The **MCH Hub modules** provide high bandwidth data communication connectivity between the AMC modules and optionally to external Switch/Hub devices via face plate interfaces.

The following variants are available:

- PCIe
- SRIO
- XAUI

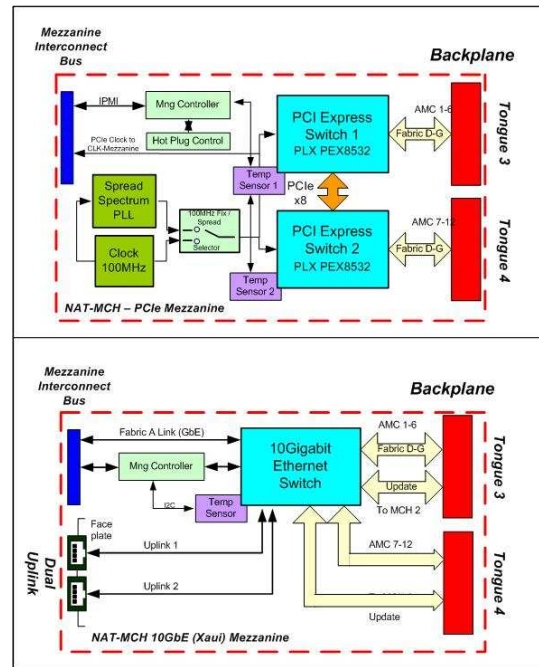
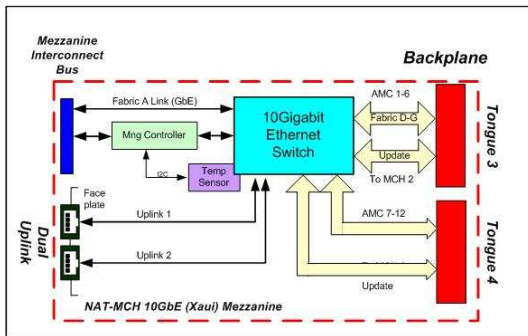

PCIe / SRIO / 10GbE Hub Mezzanines:			
Topology:	SRIO	XAUI / 10GbE	PCIe
Raw Data Rate:	1.25, 2.5, 3.125 GBit per Lane	1.25 or 3.125 GBit per Lane	2.5 GBit per Lane
Effective Data Rate / Aggregation:	x1 Port: 1, 2, 2.5 GBit/sec x4 Port : 4, 8, 10 GBit/sec	x1 Port: 1GBit/sec x4 Port: 10 GBit/sec	x1 Port: 2 GBit/sec x4 Port: 8 GBit/sec
Latency:	112ns (Cut through)	200ns (Cut through)	320ns (256 Byte Packets)
Special Functions:	Low latency packet transport Transport layer error management	VLAN (802.1D) Spanning Trre (802.1Q) Link Aggregation (802.3ad) Duplex Flow Control (802.3x) Interconnect to Fabric A Switch	Clustering Hot plug Support Dual Host Mode
Faceplate Connectors / Uplinks:	Dual Cx-4 Connector (copper)	Dual Cx-4 Connector (copper) Dual SFP+ Connector (fiber opotic)	-
Configuration:	E-Keying Script language IPMI CLI, WEB	E-Keying Script language IPMI CLI, WEB	E-Keying IPMI CLI, WEB
Power Consumption:	10W max ^(*)2)	29W max ^(*)2)	15W max ^(*)2)
Standard Compliance:	PICMG AMC.4 Rev. 1.0 PICMG AMC.0 Rev. 2.0 PICMG μTCA.0 Rev. 1.0 & 2.0 ^(*)3) PICMG SFP.0 Rev. 1.0 IPMI Specification v2.0 Rev. 1.0 EN60950, UL1950	PICMG AMC.2 Rev. 1.0 PICMG AMC.0 Rev. 2.0 PICMG μTCA.0 Rev. 1.0 & 2.0 ^(*)3) PICMG SFP.0 Rev. 1.0 IPMI Specification v2.0 Rev. 1.0 EN60950, UL1950	PICMG AMC.1 Rev. 2.0 PICMG AMC.0 Rev. 2.0 PICMG μTCA.0 Rev. 1.0 & 2.0 ^(*)3) PICMG SFP.0 Rev. 1.0 IPMI Specification v2.0 Rev. 1.0 PCIe Gen1, PCIe Gen2 ^(*)1) EN60950, UL1950
Options / Order Codes:	-SRIOx24 for 6 AMCs -SRIOx48 for 12 AMCs -Uplink	-XAUIx24 for 6 AMCs -XAUIx48 for 12 AMCs -Uplink	-PCIEx24 for 6 AMCs -PCIEx48 for 12 AMCs

(*)1): available Q1 2010, (*)2): maximum value, effective value may be lower depending on number of active ports, (*)3): in preparation

