

# General Purpose Carrier for PMC-Modules



## NCPCI-PMC

The NCPCI-PMC is a low-cost 6U CompactPCI carrier board for up to two PMC (PCI Mezzanine Card) modules especially suited for telecom and networking applications.

Due to its special design, the board can receive traditional PMCs as well as Processor PMCs (PPMC).

Designed to run in telecommunication platforms and carrier grade applications, the NCPCI-PMC is hot-swap compliant and provides the TDM H.110 bus on the backplane (PICMG 2.5).

The onboard H.110 facility enables the NCPCI-PMC to support PMCs with the SCBus on the I/O P14 connector.

# Technical Data

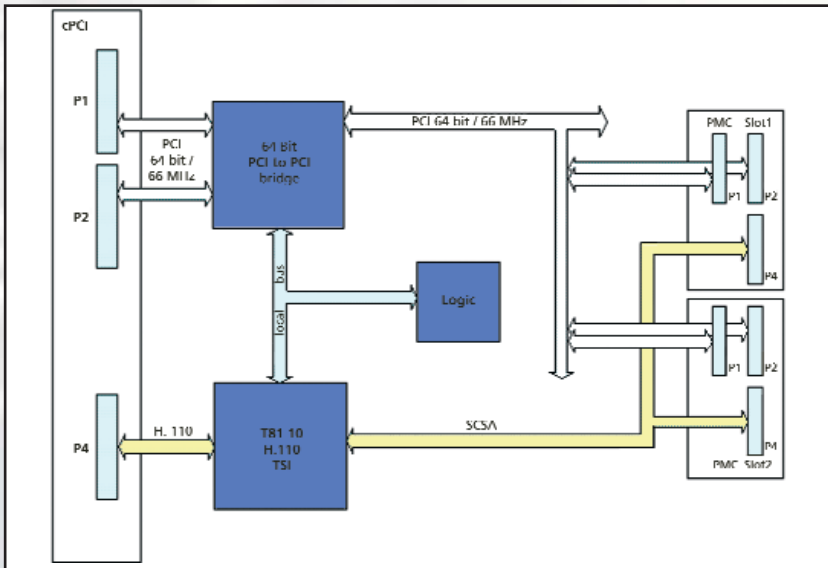

## Overview

The NCPCI-PMC is a carrier for PCI Mezzanine Cards (PMC) in 6U CompactPCI form-factor. Unlike the traditional PMC carriers, the NCPCI-PMC is well suited for running in telecommunication platforms.

The board offers the H.110 bus (PICMG2.15) allowing TDM data from and to the two PMC sites to be distributed among different peripheral boards, such as line interfaces and DSP processing boards, using this standardized bus.

Due to the fact that the power consumption of PPMCs (Processor PMCs) is higher than traditional PMCs, the NCPCI-PMC incorporates a special power supply circuitry. Thus the NCPCI-PMC is able to support PPMC modules with a power consumption up to 30W in total for both slots.

## Hardware

Using the Intel i21555 PCI-to-PCI bridge the NCPCI-PMC is a 64bit/66MHz PCI rev 2.2 compatible hot swap (PICMG 2.12) cPCI carrier for any kind of PMC module.

It offers two PCI Rev 2.2, P1386.1/Draft 2.4a compatible 32bit/33MHz PMC extension slots for use with any standard PMC module.

The NCPCI-PMC complies to PICMG 2.5 (H.110) by incorporating the Agere T8110 TSI device. The I/O connectors (P14) of the two PMC slots are connected to H.110 controller and allow PMC modules having the SCbus to directly connect to the system's TDM backplane bus on the cPCI J4 connector. Hence, any timeslot switching between the H.110 bus and the local SCSA busses is possible.

The hot swap capability of the NCPCI-PMC according to PICMG 2.1 R2.0 complies to "Full Hot Swap". PCI signals are precharged to 1V during board insertion.

Because of its special power supply circuitry, the NCPCI-PMC supports PMC modules with a power consumption of up to 30W in total, such as PPMC modules.

## PCI Interface and Compliance

Intel i21555 PCI-to-PCI bridge (66MHz, 64bit), PCI Rev. 2.2

## H.110 Bus

Agere T8110 TSI, H.110 on cPCI J4 connector, SCbus on PMC P14 connector

## PMC Slots

Two 64-bit/66 MHz PCI Rev.2.2 IEEE P1386.1 / Draft 2.4a compliant PMC slots on the PCI internal bus, I/O P14 connector used as SCSA bus connected to the T8110 TSI H.110 device.

## Hot Swap capability

Full Hot Swap

## Power Consumption

3.3V 0.5A (typ.)  
5 V 0.1A (typ.)

The +3.3V supply for PMCs is derived from the 5V supply by onboard switching regulator.

## Environmental

Temperature (operating): 0°C to +60°C with forced air cooling,  
Temperature (storage): -40°C to +85°C  
Relative Humidity: 10% to 95% at +55°C (non-condensing)

## Standard Compliance

PCI Rev. 2.2

PICMG2.1 R2.0  
PICMG 2.5 R1.0  
IEEE P1386.1 / Draft 2.4a

N.A.T.

Gesellschaft für Netzwerk- und Automatisierungs-Technologie mbH  
Kamillenweg 22 • 53757 Sankt Augustin, Germany • Phone: +49-22 41/39 89-0  
Fax: +49-22 41/39 89-10 • sales@nateurope.com • www.nateurope.com

