

**NPMC-8280-4E1/T1/J1
Telecom PMC Module
Technical Reference Manual V2.2
HW Revision 1.2, 2.0**

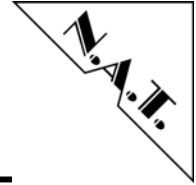

The NPMC-8280-4E1/T1/J1 has been designed by:

**N.A.T. GmbH
Kamillenweg 22
D-53757 Sankt Augustin**

Phone: ++49/2241/3989-0

Fax: ++49/2241/3989-10

**E-Mail: support@nateurope.com
Internet: <http://www.nateurope.com>**

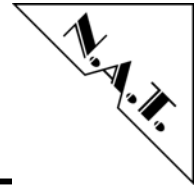

Disclaimer

The following documentation, compiled by N.A.T. GmbH (henceforth called N.A.T.), represents the current status of the product's development. The documentation is updated on a regular basis. Any changes which might ensue, including those necessitated by updated specifications, are considered in the latest version of this documentation. N.A.T. is under no obligation to notify any person, organization, or institution of such changes or to make these changes public in any other way.

We must caution you, that this publication could include technical inaccuracies or typographical errors.

N.A.T. offers no warranty, either expressed or implied, for the contents of this documentation or for the product described therein, including but not limited to the warranties of merchantability or the fitness of the product for any specific purpose.

In no event will N.A.T. be liable for any loss of data or for errors in data utilization or processing resulting from the use of this product or the documentation. In particular, N.A.T. will not be responsible for any direct or indirect damages (including lost profits, lost savings, delays or interruptions in the flow of business activities, including but not limited to, special, incidental, consequential, or other similar damages) arising out of the use of or inability to use this product or the associated documentation, even if N.A.T. or any authorized N.A.T. representative has been advised of the possibility of such damages.

The use of registered names, trademarks, etc. in this publication does not imply, even in the absence of a specific statement, that such names are exempt from the relevant protective laws and regulations (patent laws, trade mark laws, etc.) and therefore free for general use. In no case does N.A.T. guarantee that the information given in this documentation is free of such third-party rights.

Neither this documentation nor any part thereof may be copied, translated, or reduced to any electronic medium or machine form without the prior written consent from N.A.T. GmbH.

This product (and the associated documentation) is governed by the N.A.T. General Conditions and Terms of Delivery and Payment.

Note:

The release of the Hardware Manual is related to a certain HW board revision given in the document title. For HW revisions earlier than the one given in the document title please contact N.A.T. for the corresponding older Hardware Manual release.

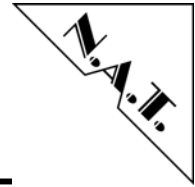
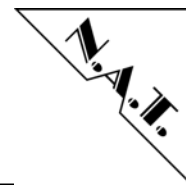
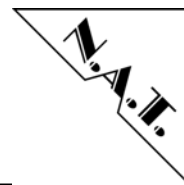

Table of Contents

LIST OF TABLES	6
LIST OF FIGURES	6
CONVENTIONS.....	7
1 INTRODUCTION.....	8
1.1 BOARD FEATURES	10
1.2 BOARD SPECIFICATION	11
2 INSTALLATION	12
2.1 SAFETY NOTE	12
2.2 INSTALLATION PREREQUISITES AND REQUIREMENTS	13
2.2.1 Requirements.....	13
2.2.2 Power supply.....	13
2.2.3 Automatic Power Up.....	13
2.3 LOCATION OVERVIEW	14
3 FUNCTIONAL BLOCKS.....	15
3.1 PROCESSOR.....	15
3.2 PCI INTERFACE	15
3.3 MEMORY	16
3.3.1 SDRAM.....	16
3.3.2 FLASH.....	17
3.3.3 I ² C Devices.....	17
3.4 H.110 BUS CONTROLLER AND LINE INTERFACES	18
3.4.1 TDM Structure of NPMC-8280-4E1/T1/J1 Hardware Revision 2.0	18
3.4.1.1 Block Diagramm of the TDM Structure.....	18
3.4.1.2 Description of the TDM Structure.....	19
3.4.2 SCbus Compatibility.....	20
3.4.3 E1/T1/J1 Line Interfaces	20
3.5 ETHERNET	21
4 HARDWARE.....	22
4.1 MEMORY MAP	22
4.2 DEFINITION OF POWERQUICC II PORT PINS	23
4.2.1 Signal Description.....	27
4.2.1.1 Selecting the TDM Data Path for MCC1 and MCC2	27
4.2.1.2 Selecting the ISDN Line Impedance	28
4.2.1.3 I ² C Interface Pins.....	28
4.2.1.4 Serial Line Interface Pins	28
4.2.1.5 100BaseT Configuration	29
4.2.1.6 LED Control Pins.....	29
4.2.1.7 SDRAM Configuration Pins.....	30
4.3 INTERRUPT STRUCTURE.....	31
4.4 REGISTER.....	32
4.4.1 PCB Revision Register	32
4.4.2 Lattice Revision Register.....	32
4.4.3 I/O Register.....	32
4.5 FRONT PANEL AND LEDS	33



5	CONNECTORS.....	34
5.1	CONNECTOR OVERVIEW	34
5.2	CONNECTOR JP1: BDM AND JTAG CONNECTOR	35
5.3	CONNECTOR JP2: LATTICE PROGRAMMING PORT	36
5.4	DIL SWITCH SW1: FLASH PROGRAMMING ENABLE SWITCH	36
5.5	PMC CONNECTOR P11	37
5.6	PMC CONNECTOR P12	38
5.7	PMC CONNECTOR P14 (PMC I/O).....	39
5.8	THE FRONT PANEL CONNECTORS (S1 – S4)	40
6	NPMC-8280-4E1/T1/J1 PROGRAMMING NOTES	41
6.1	CPU - PLL-SETUP.....	41
6.2	HARD RESET CONFIGURATION WORD	41
6.2.1	Core Enabled Mode (default).....	41
6.2.2	Core Disabled Mode (FLASH programming mode).....	42
6.3	RECOMMENDED GENERAL CONTROL REGISTER SETUP	43
6.3.1	Register-Setup of the System Clock Control Register (SCCR).....	43
6.3.2	Register-Setup of the System Protection Control Register (SYPCR).....	43
6.3.3	Register-Setup of the Bus Configurations Register (BCR).....	43
6.3.4	Register-Setup of the 60x Bus Arbiter Configurations Register (PPC_ACR)	44
6.3.5	Register-Setup of the Local Bus Arbiter Configurations Register (LCL_ACR)	44
6.3.6	Register-Setup of the SIU Module Configurations Register (SIUMCR).....	44
6.3.7	Register-Setup of the 60x Bus Transfer Status/Control Register (TESCR1)	45
6.3.8	Register-Setup of the Local Bus Transfer Status/Control Register (L_TESCR1).....	45
6.4	RECOMMENDED REGISTER SETUP OF THE MEMORY CONTROLLER:	46
6.4.1	Base Registers BRx:	46
6.4.2	Option Registers ORx.....	49
6.4.3	Configuration for SDRAM Register Setup	51
6.4.4	SDRAM Mode Register PSDMRx.....	52
6.4.5	PSRT 60x Bus-Assigned SDRAM Refresh Timer Register	52
6.4.6	MPTPR Memory Refresh Timer Prescaler Register	52
6.4.7	UPM Machine Mode Register MxMR.....	52
6.5	SETUP OF THE SERIAL INTERFACES.....	53
6.5.1	RS232 Interface on the Front Panel Connector S4	53
6.5.2	RS232 Debug Interface	53
6.5.3	I ² C Interface.....	53
6.5.4	SPI Interface.....	53
6.6	DEFINITION OF THE MULTI-FUNCTION PINS	54
7	KNOWN BUGS / RESTRICTIONS	54
8	DIFFERENCES BETWEEN HARDWARE REVISIONS 1.4 AND 2.0	55
8.1	H.110 BUS CONTROLLER AND LINE INTERFACES	56
8.1.1	Block Diagramm of the TDM Structure	56
8.1.2	Description of the TDM Structure.....	56
8.2	DEFINITION OF POWERQUICC II PORT PINS	57
8.2.1	Signal Description.....	58
8.2.1.1	Selecting the TDM Data Path for LD0 - 3.....	58
8.2.1.2	Selecting the ISDN Line Impedance	58
8.3	REGISTER.....	59
8.3.1	Lattice Revision Register.....	59
APPENDIX A: REFERENCE DOCUMENTATION.....		60
APPENDIX B: DOCUMENT'S HISTORY.....		61



List of Tables

Table 1:	List of used abbreviations	7
Table 2:	NPMC-8280-4E1/T1/J1 Features.....	11
Table 3:	TDM Channel \leftrightarrow LDI/O Data Line Connection.....	19
Table 4:	TDM Channel \leftrightarrow LDI/O Data Line Connection.....	20
Table 5:	Memory Map.....	22
Table 6:	PowerQUICC II Port Pin Usage (Port A)	23
Table 7:	PowerQUICC II Port Pin Usage (Port B).....	24
Table 8:	PowerQUICC II Port Pin Usage (Port C).....	25
Table 9:	PowerQUICC II Port Pin Usage (Port D)	26
Table 10:	Supported SDRAM SODIMM Module Types.....	30
Table 11:	BNKSELx Programming	30
Table 12:	Interrupt Structure	31
Table 13:	I/O Register	32
Table 14:	Development Port / BDM and IEEE 1149.1 Connector Pinout.....	35
Table 15:	Lattice programming port.....	36
Table 16:	PMC Connector P11.....	37
Table 17:	PMC Connector P12.....	38
Table 18:	PMC Connector P14.....	39
Table 19:	Pin Assignment of the Front-panel Connectors S1 (ISDN)	40
Table 20:	Pin Assignment of the Front-panel Connectors S2 (ISDN)	40
Table 21:	Pin Assignment of the Front-panel Connectors S3 (Ethernet).....	40
Table 22:	Pin Assignment of the Front-panel Connectors S4 (RS232).....	40
Table 23:	Hard Reset Configuration Word (as read from CPLD).....	41
Table 24:	Definition of the Multi-Function Pins.....	54
Table 25:	PowerQUICC II Port Pin Usage (Port A)	57
Table 26:	PowerQUICC II Port Pin Usage (Port C).....	57

List of Figures

Figure 1:	NPMC-8280-4E1/T1/J1 on a carrier board (VMEbus, cPCI).....	8
Figure 2:	NPMC-8280-4E1/T1/J1 Block Diagram.....	9
Figure 3:	Location diagram of the NPMC-8280-4E1/T1/J1.....	14
Figure 4:	Address / Data Paths to onboard Devices	16
Figure 5:	Local TDM Bus Organisation and Synchronisation	18
Figure 6:	Front Panel and LEDs	33
Figure 7:	Connectors of the NPMC-8280-4E1/T1/J1.....	34
Figure 8:	Local TDM Bus Organisation and Synchronisation	56

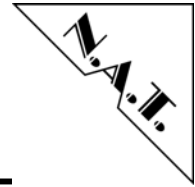

Conventions

If not otherwise specified, addresses and memory maps are written in hexadecimal notation, identified by *0x*.

Table 1 gives a list of the abbreviations used in this document:

Table 1: List of used abbreviations

Abbreviation	Description
60x bus	PowerPC processor bus
b	Bit, binary
B	byte
CPU	Central Processing Unit
DMA	Direct Memory Access
E1	2,048 Mbit G.703 Interface
Flash	Programmable ROM
H.110	Time-Slot Interchange Bus
J1	1,544 Mbit G.703 Interface (Japan)
K	kilo (factor 400 in hex, factor 1024 in decimal)
LIU	Line Interface Unit
M	mega (factor 10,000 in hex, factor 1,048,576 in decimal)
MHz	1,000,000 Herz
MPC8265, MPC8266, MPC8280	Embedded processor from Motorola
PowerQUICC II	MPC8265, MPC8266, MPC8280
RAM	Random Access Memory
ROM	Read Only Memory
SCbus	Time-Slot Interchange Bus of the SCSA, subset of H.110 bus
SCC	Serial Communication Controller of the MPC8280
SCSA	Signal Computing System Architecture
SDRAM	Synchronous Dynamic RAM
SMC	Serial Communication Controller of the MPC8280
T1	1,544 Mbit G.703 Interface (USA)
TDM	Time Division Multiplex
TSI	Time Slot Interchange
TSA	Time Slot Assigner

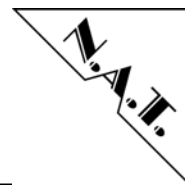

1 Introduction

The NPMC-8280-4E1/T1/J1 is a high performance standard CPU PCI Mezzanine Card Type 1. It can be plugged onto any carrier board supporting PMC standards:

Figure 1: NPMC-8280-4E1/T1/J1 on a carrier board (VMEbus, cPCI)

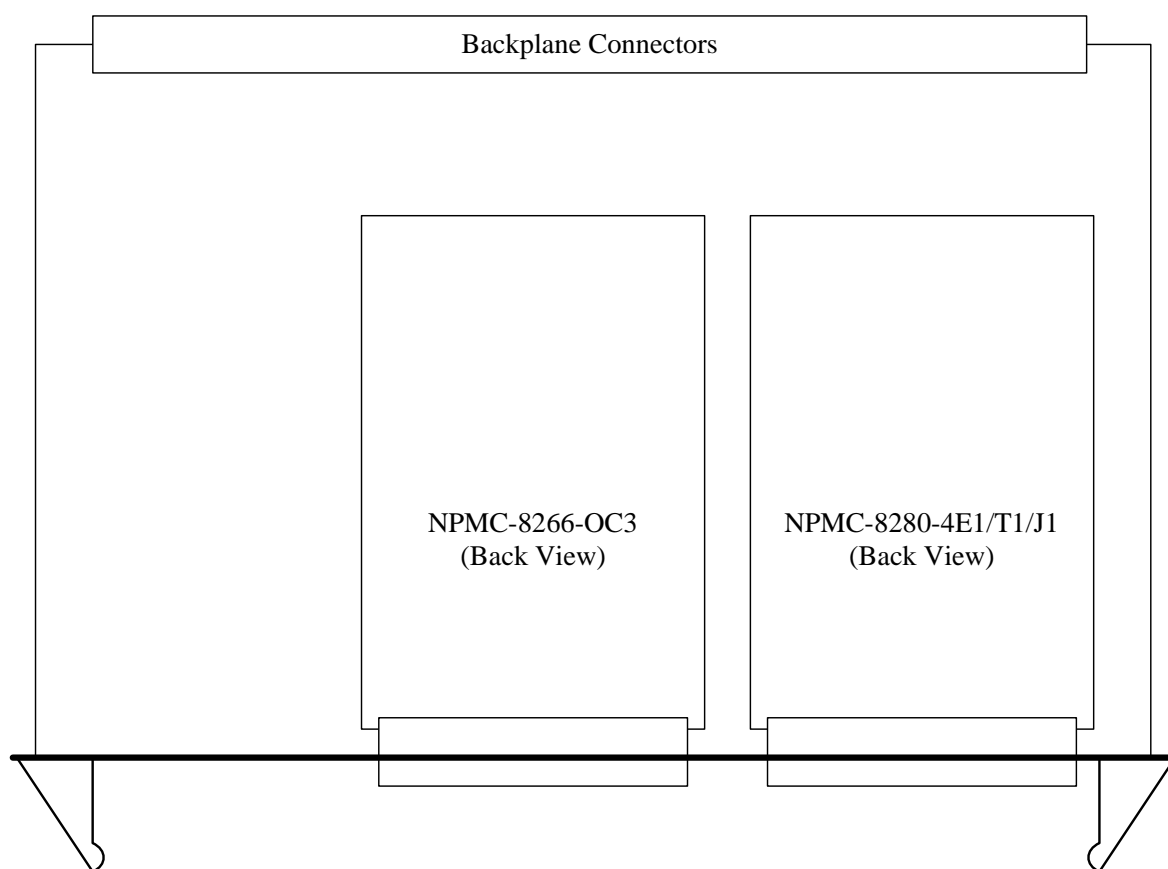

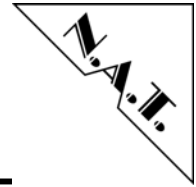

The NPMC-8280-4E1/T1/J1 has the following major features on-board:

- PowerQUICC II MPC8280 based Embedded PowerPC Architecture
- Front-panel I/O
- 32 bit / 66 MHz PCI Bus interface Rev. 2.2
- 4 x E1 / T1 / J1 primary rate line interface
- 100BaseT Ethernet channel
- H.110 / SCSA TSI bus
- SPI bus
- 32 – 256 MB main memory (SDRAM)
- 4 – 32 MB FLASH

Figure 2: NPMC-8280-4E1/T1/J1 Block Diagram

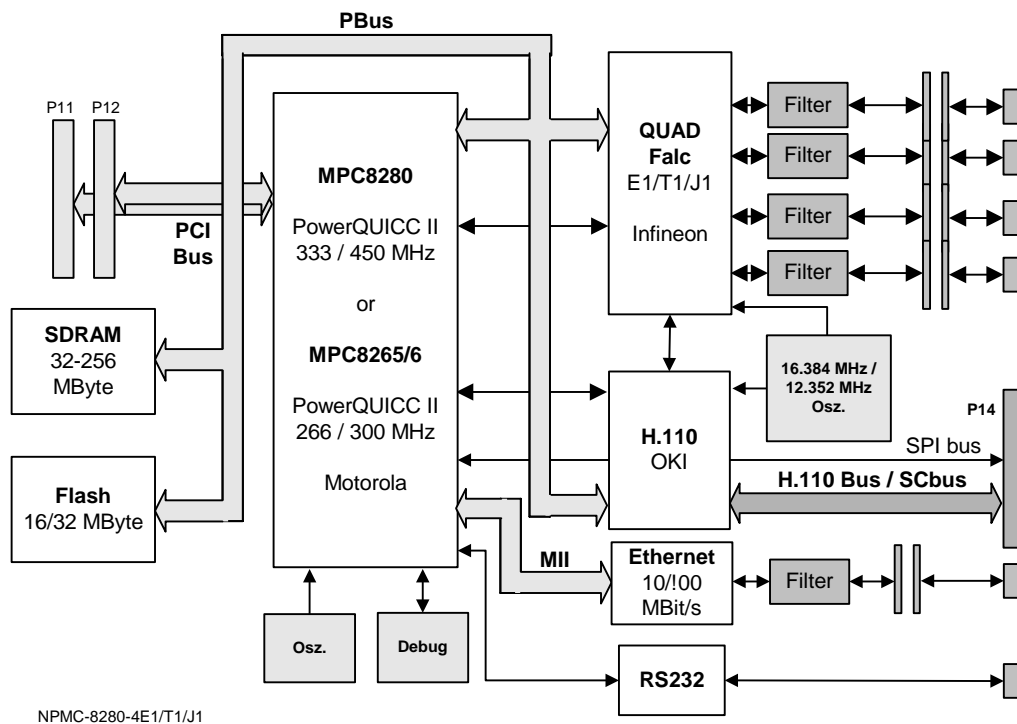

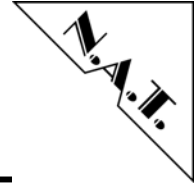

1.1 Board Features

- **CPU**

Depending on the assembled CPU the PowerQUICC II runs with a core clock frequency of 266 - 450 MHz. The user may choose between a MPC8280 or a MPC8265/8266 CPU with a core clock frequency of up to 300 MHz (assembly option).

- **Memory**

SDRAM: The **NPMC-8280-4E1/T1/J1** provides 32 to 256 MB SDRAM onboard. The SDRAM is installed as a SODIMM SDRAM module. PC100-type modules of 32 MB, 64 MB, 128 MB, and 256 MB are supported. The SDRAM is 64 bit wide.

Default: 64 MB installed

Flash PROM: The 16 bit wide Flash PROM provides a capacity of 4 - 32 MB (assembly option).

Default: 16 MB installed

- **Interfaces**

PCI: The **NPMC-8280-4E1/T1/J1** includes a 32 bit 33/66 MHz PCI bus interface. This is implemented in the MPC8280 CPU.

H.110/SCSA: The **NPMC-8280-4E1/T1/J1** implements a 32 bit H.110 interface, which includes a SCbus interface on I/O-connector P14 according to PMC specifications. This is implemented by an OKI ML53812-2 TSI device.

SPI: The **NPMC-8280-4E1/T1/J1** implements a SPI bus interface on the PMC I/O connector P14

- **I/O**

E1/T1/J1: The module carries a PEB22554 (QuadFALC) framer, which implements four E1/T1/J1 interfaces.

Ethernet: The 100 Mbit Ethernet MII interface supplied by the PowerQUICC II is connected to a 100BaseT interface through a LXT972 framer device.

RS232: There are 2 RS232 interfaces available on the **NPMC-8280-4E1/T1/J1**:

- a RS232 interface (SCC1) on the front panel
- a RS232 interface (SMC1) sharing a connector with the BDM / JTAG interface

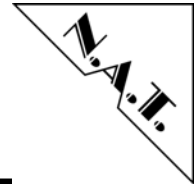

1.2 Board Specification

Table 2: NPMC-8280-4E1/T1/J1 Features

Processor	PowerQUICC II MPC8280 (333 or 450 MHz) or MPC8265/8266 (266 or 300 MHz) based Embedded PowerPC Architecture
PMC-Module	Standard PCI Mezzanine Card Type 1
Front-I/O	3 RJ45 connectors, 1 Mini-USB connector
Main Memory	32 - 256 MByte SDRAM PC100-type
Flash PROM	4 – 32 MByte Flash PROM. On board programmable
Firmware	OK1, VxWorks BSP (on request)
Power consumption (with MPC8265 / 300 MHz)	3.3V 0.85A typ. 5.0V 0.55A typ.
Environmental conditions	Temperature (operating): 0°C to +60°C with forced cooling Temperature (storage): -40°C to +85°C Humidity: 10 % to 90 % rh noncondensing
Standards compliance	PCI Rev. 2.2 P1386.1 / Draft 2.4a

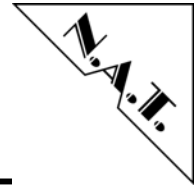

2 Installation

2.1 Safety Note

To ensure proper functioning of the **NPMC-8280-4E1/T1/J1** during its usual lifetime take the following precautions before handling the board.

CAUTION

Electrostatic discharge and incorrect board installation and uninstallation can damage circuits or shorten their lifetime.

- Before installing or uninstalling the **NPMC-8280-4E1/T1/J1** read this installation section
- Before installing or uninstalling the **NPMC-8280-4E1/T1/J1**, read the Installation Guide and the User's Manual of the carrier board used
- Before installing or uninstalling the **NPMC-8280-4E1/T1/J1** on a carrier board or both in a rack:
 - Check all installed boards and modules for steps that you have to take before turning on or off the power.
 - Take those steps.
 - Finally turn on or off the power.
- Before touching integrated circuits ensure to take all require precautions for handling electrostatic devices.
- Ensure that the **NPMC-8280-4E1/T1/J1** is connected to the carrier board via all PMC connectors and that the power is available on both PMC connectors (GND, +5V, and +3,3V).
- When operating the board in areas of strong electromagnetic radiation ensure that the module
 - is bolted the front panel or rack
 - and shielded by closed housing

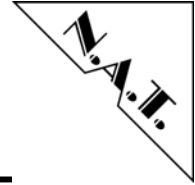

2.2 Installation Prerequisites and Requirements

IMPORTANT

Before powering up

- check this section for installation prerequisites and requirements

2.2.1 Requirements

The installation requires only

- a carrier board for connecting the **NPMC-8280-4E1/T1/J1**
- power supply

2.2.2 Power supply

The power supply for the **NPMC-8280-4E1/T1/J1** must meet the following specifications:

- required for the module:
 - +3,3V / 0.85A typical
 - +5,0V / 0.55A typical

2.2.3 Automatic Power Up

In the following situations the **NPMC-8280-4E1/T1/J1** will automatically be reset and proceed with a normal power up.

Voltage sensors

The voltage sensor generates a reset

- when +5V voltage level drops below 4,4V *
- when +5V voltage level rises above 5,6V *
- when +3.3V voltage level drops below 2,65V *
- when +3.3V voltage level rises above 3,9V *
- or when the carrier board signals a PCI Reset

Watchdog (if enabled)

* defined by: “PCI Specification Revision 2.2, Section 4.2.1.1 and Section 4.3.2”

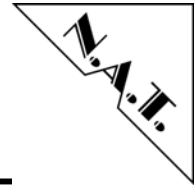

2.3 Location Overview

The figure 3 "Location diagram of the NPMC-8280-4E1/T1/J1" highlights the position of the important components. Depending on the board type it might be that the board does not include all components named in the location diagram.

Figure 3: Location diagram of the NPMC-8280-4E1/T1/J1

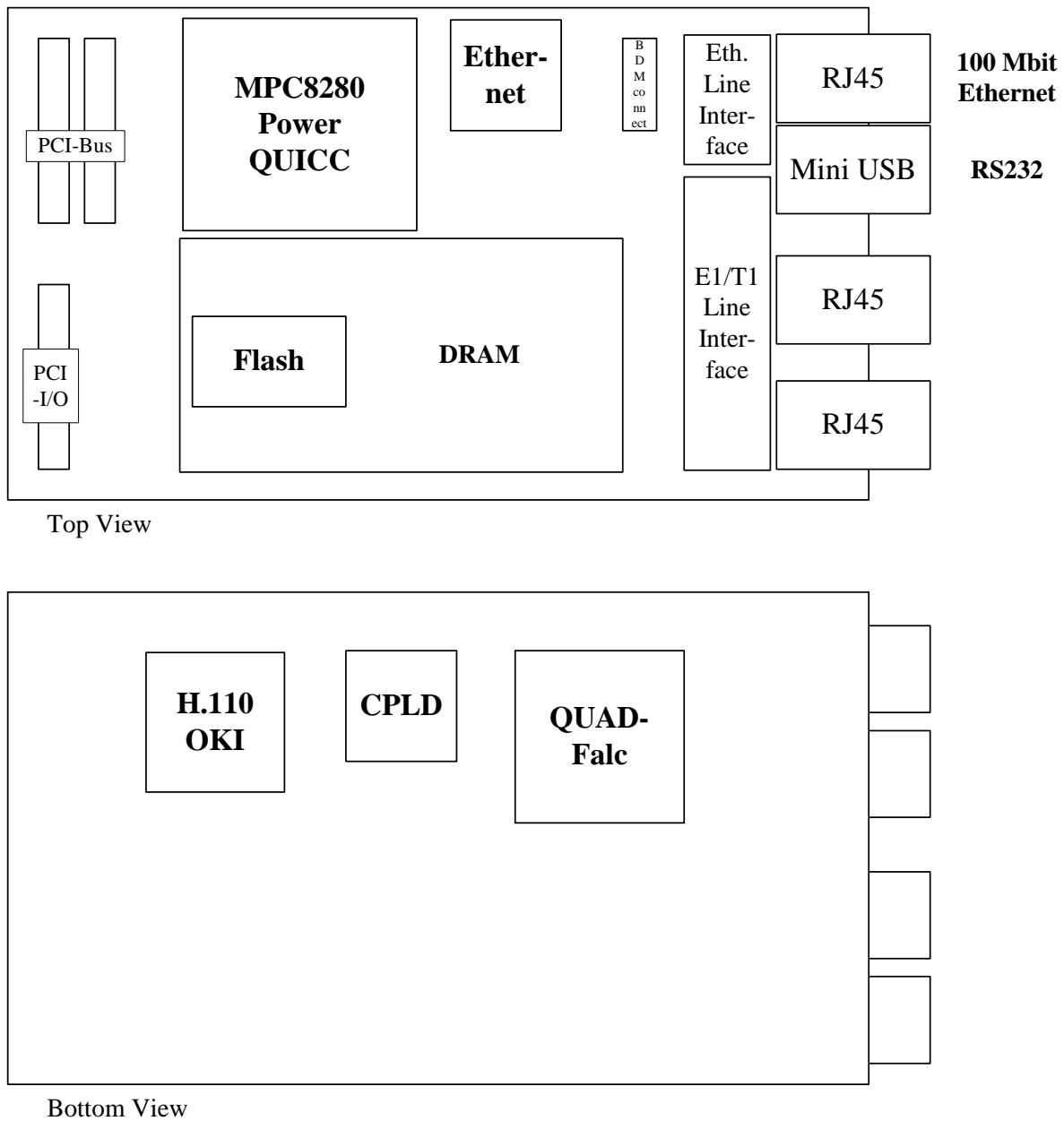

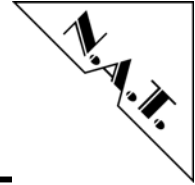

3 Functional Blocks

The **NPMC-8280-4E1/T1/J1** can be divided into a number of functional blocks, which are described in the following paragraphs.

3.1 Processor

The MPC8280 PowerQUICC II™ is a versatile communications processor that integrates on one chip a high-performance PowerPC™ RISC microprocessor, a very flexible system integration unit, and many communications peripheral controllers that can be used in a variety of applications, particularly in communications and networking systems.

The core is an embedded variant of the PowerPC MPC603e™ microprocessor with 16 Kbytes of instruction cache and 16 Kbytes of data cache and no floating-point unit (FPU). The system interface unit (SIU) consists of a flexible memory controller that interfaces to almost any user-defined memory system, and many other peripherals making this device a complete system on a chip.

The communications processor module (CPM) includes four serial communications controllers (SCCs) , with the addition of three high-performance communication channels that support new emerging protocols (for example, 155 Mbps ATM and Fast Ethernet). The MPC8280 has dedicated hardware that can handle up to 256 full-duplex, time-division-multiplexed logical channels, as well as DMA functionality executing memory to memory and memory to I/O transfers.

3.2 PCI Interface

The MPC8280 integrates a 32 bit, 33/66 MHz PCI interface.

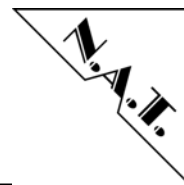

3.3 Memory

3.3.1 SDRAM

As the onboard SDRAM memory has to be accessed not only by the CPU, but also by the host through the PCI bridge, external address latches and multiplexers had to be implemented. The structure is shown in Figure 4 below.

Figure 4: Address / Data Paths to onboard Devices

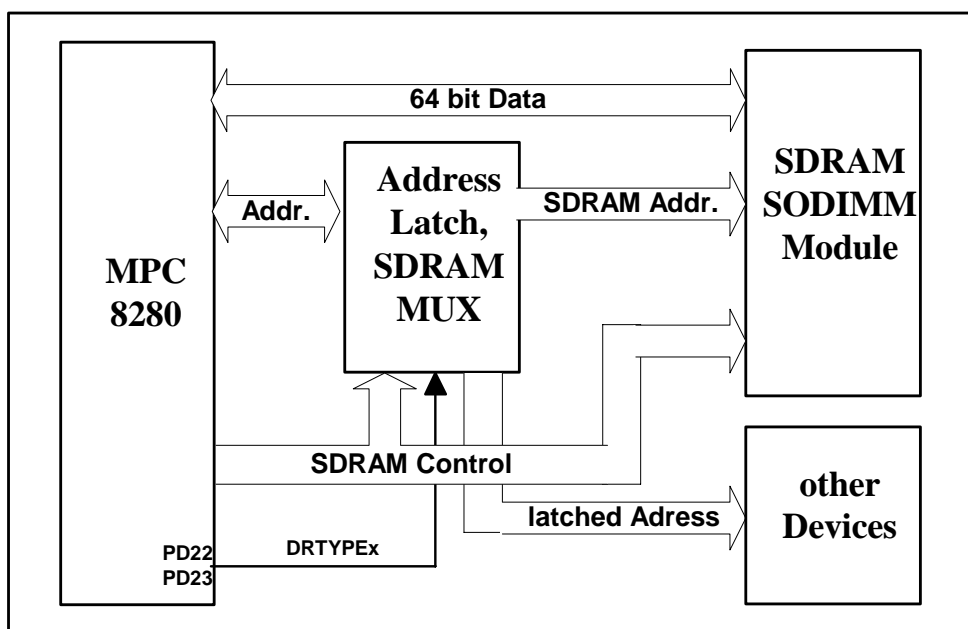

The SDRAM is connected to the 60x bus interface of the MPC8280. The multiplexer organization can be adjusted to different SDRAM types by the DRTYPEx selection signals. Suitable SDRAM modules must be of PC100 or PC133 type. Refer to **Chapter 4**, Table 10: , and Table 11: for further information on SODIMM modules.

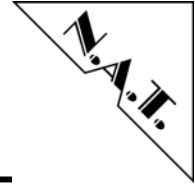

3.3.2 FLASH

FLASH memory is connected to the upper 16 data bits D0 – 15 and to the latched address lines. The FLASH on the **NPMC-8280-E1/T1/J1** can be programmed either by the CPU (by appropriate software or through the BDM port) or by a PCI bus master. In the latter case the PowerQUICC II has to be prevented from booting from FLASH while it does not contain a defined boot program, in order not to enter unknown states. This can be achieved by setting a DIL switch (SW1), which disables the MPC8280 CPU core after the following Power-Up cycle. This feature is used for programming the FLASH memory on the **NPMC-8280-E1/T1/J1** via the PCI bus. If switch no. 1 of SW1 is set to 'ON' the Hardware Configuration Words for the CPU are loaded from an onboard CPLD. Some basic register setup is performed using the 'Autoload' function of the MPC8280. Once the FLASH has been programmed, SW1 / 1 has to be set to 'OFF' again. If the FLASH contains valid boot code, it may be reprogrammed without having to use SW1. Programming software is available on request. Please refer to section 5.4 for details on DIL switch SW1, and to section 6.2 for details on the Hardware Configuration Words.

3.3.3 I²C Devices

There are two I²C devices on the **NPMC-8280-E1/T1/J1**, which are connected to the MPC8280 I²C bus; an EEPROM used for storage of board-specific information, and the EEPROM on the SODIMM SDRAM module, which contains vital data about the SDRAM module size and address organisation. This information is necessary, in order to be able to program the SDRAM controller functions appropriately. The EEPROM on the SODIMM typically defaults to a 24C02 type, the EEPROM for storage of board-specific information defaults to a 24C08 device. The address of the EEPROM on the SDRAM SODIMM module is 0x0, the address of the other EEPROM is 0x4.

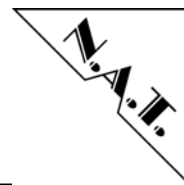

3.4 H.110 Bus Controller and Line Interfaces

Due to differences concerning the TDM bus organisation and structure, as well as the possibilities of TDM signal routing between Hardware Revisions 1.2 and 2.0 of the **NPMC-8280-4E1/T1/J1** this chapter had to be separated into 2 parts, each describing one HW revision. As with all chapters describing different hardware behaviour, please refer to chapter 8 for details.

3.4.1 TDM Structure of NPMC-8280-4E1/T1/J1 Hardware Revision 2.0

3.4.1.1 Block Diagramm of the TDM Structure

Figure 5: Local TDM Bus Organisation and Synchronisation

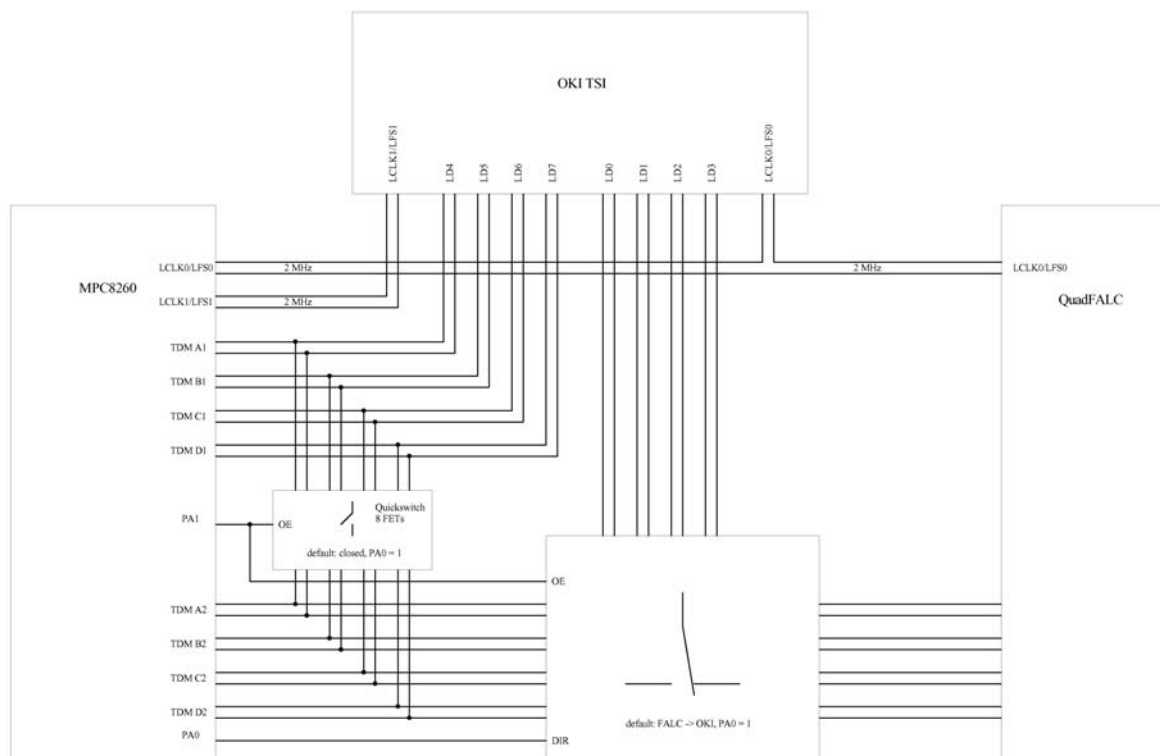

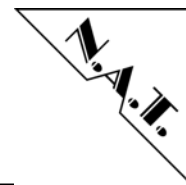

3.4.1.2 Description of the TDM Structure

The TDM data are routed through the ML53812-2 TSI device. Hence, any timeslot switching between H.110 bus, framers, and CPU is possible. Local TDM data lines LDI[0 – 3] and LDO[0 – 3] are routed between QuadFALC and TSI and CPU. In order to prevent data distortion the data outputs of the QuadFALC may be isolated from the TDM bus, if all 8 TDM lines are to be used between TSI and CPU. The switch element connecting the QuadFALC data lines LDI[0 – 3] is enabled by programming CPU port pin PA0. Default: PA0 = 1, QuadFALC data lines LDI[0 – 3] enabled.

For compatibility reasons to earlier versions of the **NPMC-8280-4E1/T1/J1** there is another switch element that connects MPC8280's TDMx1 signals with TDMx2 signals. This feature is enabled by programming CPU port pin PA1. Default: PA1 = 1, MPC8280's TDMx1 signals connected to with TDMx2 signals.

The connection between the TDM data lines LDI[0 – 7] / LDO[0 – 7] and the corresponding TDM channels of the MPC8280 for PA1 = 0 is shown in the following table:

Table 3: TDM Channel ↔ LDI/O Data Line Connection

MPC8280 TDM Channel	TDM data line LDIx/LDOx	Sync for TDM Channel	Clock for TDM Channel
TDM_A1	LDI/O[4]	L_FS0	L_CLK0
TDM_B1	LDI/O[5]	L_FS0	L_CLK0
TDM_C1	LDI/O[6]	L_FS0	L_CLK0
TDM_D1	LDI/O[7]	L_FS0	L_CLK0
TDM_A2	LDI/O[0]	L_FS1	L_CLK1
TDM_B2	LDI/O[1]	L_FS1	L_CLK1
TDM_C2	LDI/O[2]	L_FS1	L_CLK1
TDM_D2	LDI/O[3]	L_FS1	L_CLK1

The connection between the TDM data lines LDI[0 – 7] / LDO[0 – 7] and the corresponding TDM channels of the MPC8280 for PA1 = 1 is shown in the following table:

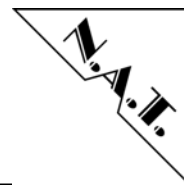

Table 4: TDM Channel ↔ LDI/O Data Line Connection

MPC8280 TDM Channel	TDM data line LDIx/LDOx	Sync for TDM Channel	Clock for TDM Channel
TDM_A1	LDI/O[4]	L_FS0	L_CLK0
TDM_B1	LDI/O[5]	L_FS0	L_CLK0
TDM_C1	LDI/O[6]	L_FS0	L_CLK0
TDM_D1	LDI/O[7]	L_FS0	L_CLK0
TDM_A2	LDI/O[4]	L_FS1	L_CLK1
TDM_B2	LDI/O[5]	L_FS1	L_CLK1
TDM_C2	LDI/O[6]	L_FS1	L_CLK1
TDM_D2	LDI/O[7]	L_FS1	L_CLK1

The Sync and Clock signals L_FS[0-1] and L_CLK[0-1] can be programmed within the OKI TSI local clock and local sync settings.

The TSI device derives its time base from one of the LREF signals coming from the framers, or from the H.110 bus. From this input it generates local clock and frame sync for the framers and the CPU to synchronize to. Timing reference for offboard routing devices can be provided by programming one of the local LREF signals to be output on one of the NETREFx signals. For detailed information please refer to the Motorola MPC8280, OKI ML53812-2, and Infineon PEB22554 User's Manuals.

3.4.2 SCbus Compatibility

The SCbus implemented on the **NPMC-8280-4E1/T1/J1** is a sub-set of the H.110 bus. SCbus data lines correspond to H.110 data lines CT_D[0 – 15]. See chapter 5.7 (PMC P14 Connector) for reference. As an assembly option either the H.110 reference signal NETREF1 or NETREF2 may be connected to the corresponding SCbus signal SREF_8K. By default, NETREF1 is connected to SREF_8K.

3.4.3 E1/T1/J1 Line Interfaces

The four E1/T1/J1 interfaces connect the Infineon QuadFALC framer to the front panel RJ45 connectors. Timing and interface characteristics can be set up by software within the QuadFALC, the correct line impedance is selected by programming the IMPSELA and IMPSELB port signals as described below in chapter 4.2.1.2. The line interfaces conform to EN60950 and G.703.

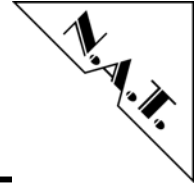

3.5 Ethernet

The LXT972 Ethernet LIU is connected to the MPC8280 through the MII interface. It connects to the front panel connector S3.

Configuration settings of the LXT972 are done by MPC8280 port pins. This applies to signals TxSLEW_x, PAUSE, and PWRDWN. Refer to Table 9: for details. ADDR0 is grounded.

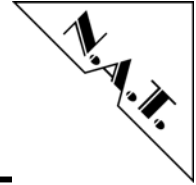

4 Hardware

4.1 Memory Map

All addresses are set up by programming the corresponding Chip-Select Decoder of the PowerQUICC.

Table 5: Memory Map

Device	CS Line	Address	Function	Notes
main FLASH	CS0	programmable	Boot, user code	4/8/16/32 MByte Flash-Prom (16 bit wide)
not used	CS1	programmable	Boot, user code	not used
SDRAM	CS2	programmable	main memory, CS2 and CS3 share the same SODIMM	32 - 256 MByte SDRAM (64 bit wide)
SDRAM	CS3	programmable		
Register	CS4	programmable	PCB version, I/O setup, reset	8 bit wide
ML53812	CS5	programmable	H.110 TSI	8 bit wide
PEB22554	CS6	programmable	QuadFALC	8 bit wide
not used	CS7	not used		
not used	CS8	not used		
not used	CS9	not used		
not used	CS10	not used		
not used	CS11	not used		

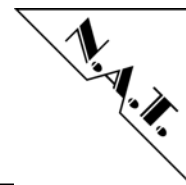

4.2 Definition of PowerQUICC II Port Pins

PowerQUICC II port pins are used to communicate with the framers and to set up some board configuration. In detail:

Table 6: PowerQUICC II Port Pin Usage (Port A)

Signal Function	PowerQUICC II Port A Pin	Description
Ethernet MII COL	PA31	MII interface to the 100 Mbit transceiver LXT972
Ethernet MII CRS	PA30	MII interface
Ethernet MII TX ER	PA29	MII interface
Ethernet MII TX EN	PA28	MII interface
Ethernet MII RX DV	PA27	MII interface
Ethernet MII RX ER	PA26	MII interface
Ethernet MII MDC	PA25	MII interface
Ethernet MII MDIO	PA24	MII interface
	PA23	
	PA22	
Ethernet MII TXD3	PA21	MII interface
Ethernet MII TXD2	PA20	MII interface
Ethernet MII TXD1	PA19	MII interface
Ethernet MII TXD0	PA18	MII interface
Ethernet MII RXD3	PA17	MII interface
Ethernet MII RXD2	PA16	MII interface
Ethernet MII RXD1	PA15	MII interface
Ethernet MII RXD0	PA14	MII interface
	PA13	
	PA12	
	PA11	
	PA10	
TSI LDI4	PA9	Time Slot Assigner Bus data bit 4, output of the MPC8280, input to the ML53812 H.110 controller (Time Slot Interchange (TSI))
TSI LDO4	PA8	Time Slot Assigner Bus data bit 4, input to the MPC8280, output of the ML53812 H.110 controller (Time Slot Interchange (TSI))
TSI L_FS	PA7	Time Slot Assigner frame sync, input to the MPC8280, output of the ML53812 H.110 controller
TSI L_FS	PA6	TSA frame sync
	PA5	
	PA4	

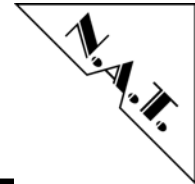

TSI L_CLK1	PA3	Time Slot Assigner alternate clock, input to the MPC8280, output of the ML53812 H.110 controller
TSI L_CLK1	PA2	TSA alternate clock
TDM_DP1*	PA1	setup TDM data path between the TSI data lines, the MCCs, the QuadFALC
TDM_DP0*	PA0	setup TDM data path between the TSI data lines, the MCCs, the QuadFALC

Table 7: PowerQUICC II Port Pin Usage (Port B)

Signal Function	PowerQUICC II Port B Pin	Description
TSI LDI1	PB31	TSA data bus bit 1, TSI in
TSI LDO1	PB30	TSA data bus bit 1, TSI out
TSI L_FS1	PB29	TSA alternate frame sync
TSI L_FS1	PB28	TSA alternate frame sync
TSI LDI2	PB27	TSA data bus bit 2, TSI in
TSI LDO2	PB26	TSA data bus bit 2, TSI out
TSI L_FS1	PB25	TSA alternate frame sync
TSI L_FS1	PB24	TSA alternate frame sync
TSI LDI3	PB23	TSA data bus bit 3, TSI in
TSI LDO3	PB22	TSA data bus bit 3, TSI out
TSI L_FS1	PB21	TSA alternate frame sync
TSI L_FS1	PB20	TSA alternate frame sync
	PB19	
	PB18	
TSI L_CLK1	PB17	TSA alternate clock
TSI L_CLK1	PB16	TSA alternate clock
TSI LDI6	PB15	TSA data bus bit 6, TSI in
TSI LDO6	PB14	TSA data bus bit 6, TSI out
TSI L_FS	PB13	TSA frame sync
TSI L_FS	PB12	TSA frame sync
TSI LDI7	PB11	TSA data bus bit 7, TSI in
TSI LDO7	PB10	TSA data bus bit 7, TSI out
TSI L_FS	PB9	TSA frame sync
TSI L_FS	PB8	TSA frame sync
TSI LDI0	PB7	TSA data bus bit 0, TSI in
TSI LDO0	PB6	TSA data bus bit 0, TSI out
TSI L_FS1	PB5	TSA alternate frame sync
TSI L_FS1	PB4	TSA alternate frame sync

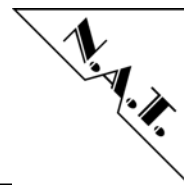

Table 8: PowerQUICC II Port Pin Usage (Port C)

Signal Function	PowerQUICC II Port C Pin	Description
TSI L_CLK	PC31	Time Slot Assigner clock, input to the MPC8280, output of the ML53812
TSI L_CLK	PC30	TSA clock
TSI L_CLK	PC29	TSA clock
TSI L_CLK	PC28	TSA clock
TSI L_CLK	PC27	TSA clock
TSI L_CLK	PC26	TSA clock
TSI L_CLK	PC25	TSA clock
TSI L_CLK	PC24	TSA clock
internal	PC23	do not use
Ethernet MII TXCLK	PC22	MII interface
	PC21	
Ethernet MII RXCLK	PC20	MII interface
TSI L_CLK1	PC19	Time Slot Assigner alternate clock, input to the MPC8280, output of the ML53812
TSI L_CLK1	PC18	TSA alternate clock
TSI L_CLK1	PC17	TSA alternate clock
TSI L_CLK1	PC16	TSA alternate clock
	PC15	
SL_4	PC14	SCbus slot address bit
SL_3	PC13	SCbus slot address bit
SL_2	PC12	SCbus slot address bit
SL_1	PC11	SCbus slot address bit
SL_0	PC10	SCbus slot address bit
IMPSELA*	PC9	E1/T1/J1 Receive Interface Impedance Select
IMPSELB*	PC8	E1/T1/J1 Receive Interface Impedance Select
	PC7	
	PC6	
LED6*	PC5	Front Panel LED 6
LED5*	PC4	Front Panel LED 5
LED4*	PC3	Front Panel LED 4
LED3*	PC2	Front Panel LED 3
LED2*	PC1	Front Panel LED 2
LED1*	PC0	Front Panel LED 1

Signals with asterisk (*) are described in detail below.

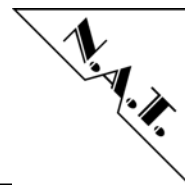
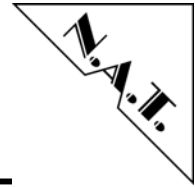

Table 9: PowerQUICC II Port Pin Usage (Port D)

Signal Function	PowerQUICC II Port D Pin	Description
RXD1_SCC*	PD31	receive data lines of the RS232 interface, SCC1
TXD1_SCC*	PD30	transmit data lines of the RS232 interface, SCC1
PAUSE*	PD29	LXT972 control function
reserved	PD28	do not use
TxSL1*	PD27	LXT972 control function
TxSL0*	PD26	LXT972 control function
	PD25	
PWRDN*	PD24	LXT972 control function
DRTYPE0*	PD23	SDRAM control function
DRTYPE1*	PD22	SDRAM control function
	PD21	
	PD20	
SPISEL	PD19	SPI Bus, Select
SPICLK	PD18	SPI Bus, Clock
SPIMOSI	PD17	SPI Bus, Data Out
SPIMISO	PD16	SPI Bus, Data In
SDA_PQ*	PD15	I ² C Bus, data
SCL_PQ*	PD14	I ² C Bus, clock
TSI LDI5	PD13	TSA data bus bit 5, TSI in
TSI LDO5	PD12	TSA data bus bit 5, TSI out
TSI L_FS	PD11	TSA frame sync
TSI L_FS	PD10	TSA frame sync
TXD1_SMC*	PD9	transmit data lines of the RS232 interface, SMC1
RXD1_SMC*	PD8	receive data lines of the RS232 interface, SMC1
	PD7	
	PD6	
	PD5	
	PD4	

Signals with asterisk (*) are described in detail below.



4.2.1 Signal Description

Port pins without signal name and description are not connected and should be programmed as outputs, signal level high, open drain.

4.2.1.1 Selecting the TDM Data Path for MCC1 and MCC2

TDM_DP1, TDM_DP0 define the data paths between the TSI TDM data lines 0 – 3, the MCCs, and the QuadFALC. Refer to Figure 5: and to the drawings below for clarification. The following truth table applies:

TDM_DP0	TDM_DP1	TDM data routing
0	0	reserved for future use
0	1	MCC1 connects to OKI TDM data lines 4 – 7, MCC2 connects to OKI TDM data lines 0 – 3, QuadFALC disconnected
1	0	reserved for future use
1	1	MCC1 and MCC2 are shorted, connect to OKI TDM data lines 4 – 7, OKI TDM data lines 0 – 3 connect to QuadFALC (<i>default</i>)

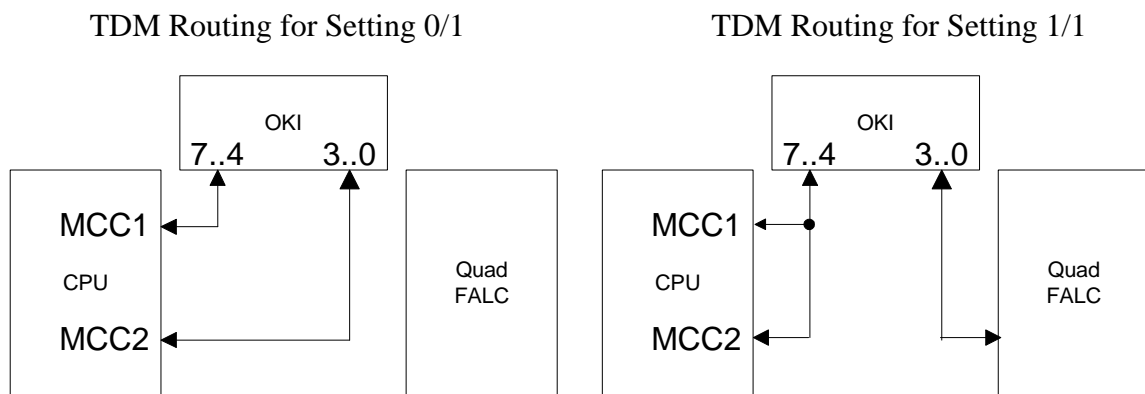

Note: This feature is available only from HW release 2.0 up. Earlier versions have TDM data lines 0 – 3 hard-wired between QuadFALC and CPU, and TDM data lines 4 – 7 hard-wired between CPU and OKI TSI.

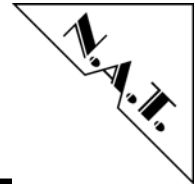

4.2.1.2 Selecting the ISDN Line Impedance

IMPSELA, Line impedance select lines used for selection of 100 Ω (T1/J1),
 IMPSELB 120 Ω (E1), or 75 Ω (E1) receiver line termination

IMPSELA	IMPSELB	receiver line termination
0	0	100 Ω (T1/J1)
0	1	75 Ω (E1)
1	0	120 Ω (E1)
1	1	no termination selected <i>(default)</i>

4.2.1.3 I²C Interface Pins

SDA_PQ, I²C interface connected to the SDRAM SODIMM EEPROM (address 0x0)
 SCL_PQ and to the general purpose EEPROM U10 (24C02, address 0x4)

4.2.1.4 Serial Line Interface Pins

RXD1_SCC, receive data line of the RS232 interface, SCC1 on PD31
 TXD1_SCC transmit data line of the RS232 interface, SCC1 on PD30
 RXD1_SMC, receive data line of the RS232 interface, SMC1 on PD8
 TXD1_SMC transmit data line of the RS232 interface, SMC1 on PD9

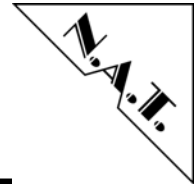

4.2.1.5 100BaseT Configuration

TxSL0, TxSL1, Port pins used for LXT972 control functions. Please refer to the LXT972 users manual for details. Possible settings are:

TxSLEW1	TxSLEW0	slew rate (rise and fall time)
0	0	2.5 ns
0	1	3.1 ns
1	0	3.7 ns
1	1	4.3 ns (<i>default</i>)

PAUSE Port pin used for LXT972 control functions. Please refer to the LXT972 users manual for details.
Pause = 1: Pause capabilities during negotiation enabled (*default*)

PWRDN Port pin used for LXT972 control functions. Please refer to the LXT972 users manual for details.
PWRDWN = 1: Power Down mode selected (*default*)

4.2.1.6 LED Control Pins

LED6 – LED1 Port pins used to control the front panel LEDs 1 – 6. Setting a port pin low (PCx = 0) turns the respective LED on, setting it high (PCx = 1) turns the respective LED off (*default*).

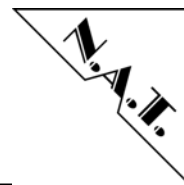

4.2.1.7 SDRAM Configuration Pins

DRTYPE0, Port pins used to set the correct multiplexing logic within Lattice U13.
DRTYPE1 These pins code the size and array information of the SDRAM module installed. The correct binary value for DRTYPE1-0 has to be determined by reading the SDRAM SODIMM EEPROM contents. This EEPROM contains also further information needed to program the SDRAM controller of the MPC8280 appropriately, e.g. row start address and clock cycles needed for SDRAM access.
 DRTYPE_x settings refer to following SODIMM organisation:

Table 10: Supported SDRAM SODIMM Module Types

DRTYPE1 (PD22)	DRTYPE0 (PD23)	highest column address to be multiplexed	no. of SDRAM column addresses
0	0	SDA7	8
0	1	SDA8	9
1	0	SDA9	10
1	1	SDA11	11

SDA_x refers to SDRAM SODIMM address pin.

Addresses to be programmed to be output on PowerQUICC II signals BNKSEL_x:

Table 11: BNKSEL_x Programming

DRTYPE1 (PD22)	DRTYPE0 (PD23)	BNKSEL2	BNKSEL1
0	0	PB_A19	PB_A20
0	1	PB_A18	PB_A19
1	0	PB_A17	PB_A18
1	1	PB_A16	PB_A17

PB_A_x refers to PowerQUICC II address line A_x. BNKSEL0 is not used.

Refer to chapter 6.3 of this manual and to the MPC8280 User’s Manual for a detailed description of how to program the Memory Controller of the MPC8280.

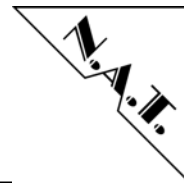

4.3 Interrupt Structure

The NPMC-8280-E1/T1/J1 has the following Interrupt structure:

Table 12: Interrupt Structure

Interrupt source	PowerQUICC Interrupt level
NC	IRQ-Level 0 (highest level)
NC	IRQ-Level 1
ML53812	IRQ-Level 2
PEB22554	IRQ-Level 3
LXT972	IRQ-Level 4
NC	IRQ-Level 5
NC	IRQ-Level 6
NC	IRQ-Level 7 (lowest level)

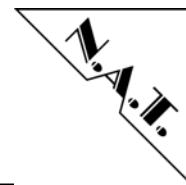

4.4 Register

4.4.1 PCB Revision Register

There is an 8 bit wide PCB revision register implemented in the CPLD onboard the **NPMC-8280-4E1/T1/J1**, which contains the revision code of the PCB. This code reads decimally-coded in 2 nibbles, i.e. the PCB version V1.0 reads 0x10. The register is addressed by the Register Chip Select CS4 as described in Table 5: with address offset 0x0.

4.4.2 Lattice Revision Register

There is an 8 bit wide Lattice CPLD revision register implemented in the CPLD onboard the **NPMC-8280-4E1/T1/J1**, which contains the revision code of the Lattice CPLD. This code reads decimally-coded in 2 nibbles, i.e. the CPLD version V1.0 reads 0x10. The register is addressed by the Register Chip Select CS4 as described in Table 5: with address offset 0x8.

4.4.3 I/O Register

There is an 8 bit wide I/O register implemented in the CPLD onboard the **NPMC-8280-4E1/T1/J1**, which serves 3 functions:

- software reset (reboot) functionality of the MPC8280 CPU, transformed by logic into a hardware reset to the CPU
- software reset of all I/O devices (QuadFALC, OKI TSI, Ethernet PHY)
- selection of E1 or T1/J1 functionality for the QuadFALC, resulting in an appropriate MCLK (2.048 or 1.544 MHz) provided

The I/O register base address is programmed by the settings for CS4. The register is 8 bits wide, read/write, but only 2 bits are used, the rest reads as 0.

Table 13: I/O Register

Bit Number	Read/Write	Status Information / Control Setting
Bit 7	R/W	1 = reset for all I/O devices, defaults to 0
Bit 6	R/W	selection of E1 or T1/J1 functionality for the QFALC 0 = E1 (default), 1 = T1/J1
Bit 5	R	not used
Bit 4	R	not used
Bit 3	R	not used
Bit 2	R	not used
Bit 1	R	not used
Bit 0	W	1 = reset for the MPC8280 CPU, defaults to 0

The register is addressed by the Register Chip Select CS4 as described in Table 5: with address offset 0x10.

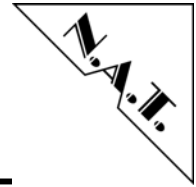

4.5 Front Panel and LEDs

The NPMC-8280-4E1/T1/J1 module is equipped with 8 LEDs, 6 of which are completely software programmable. Thus their functionality depends very much of the application running on the module.

Figure 6: Front Panel and LEDs

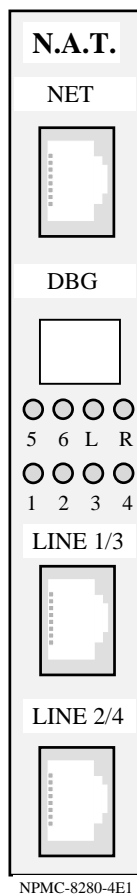

LEDs:

- LED R the red LED shows the processor Reset state:
LED lit indicates processor is in Reset state

- LED L this yellow LED shows the line status of the Ethernet connection:
LED lit shows link up.

- LED 6 - 1 the green LEDs 1 – 6 are fully software programmable and their meaning depends on user application.

Connectors:

- NET The RJ45 connector S3 connects to an 100BaseT Ethernet network.

- DBG The Mini USB connector S4 connects to an RS232 debug interface.

- LINE 1/3, These RJ45 connectors S1 and S2 carry the 4 E1/T1/J1 interfaces. Each 2 interfaces share one connector.
- LINE 2/4

Please refer to Chapter 5.8 for details on front panel connectors.

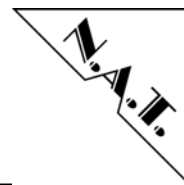

5 Connectors

5.1 Connector Overview

Figure 7: Connectors of the NPMC-8280-4E1/T1/J1

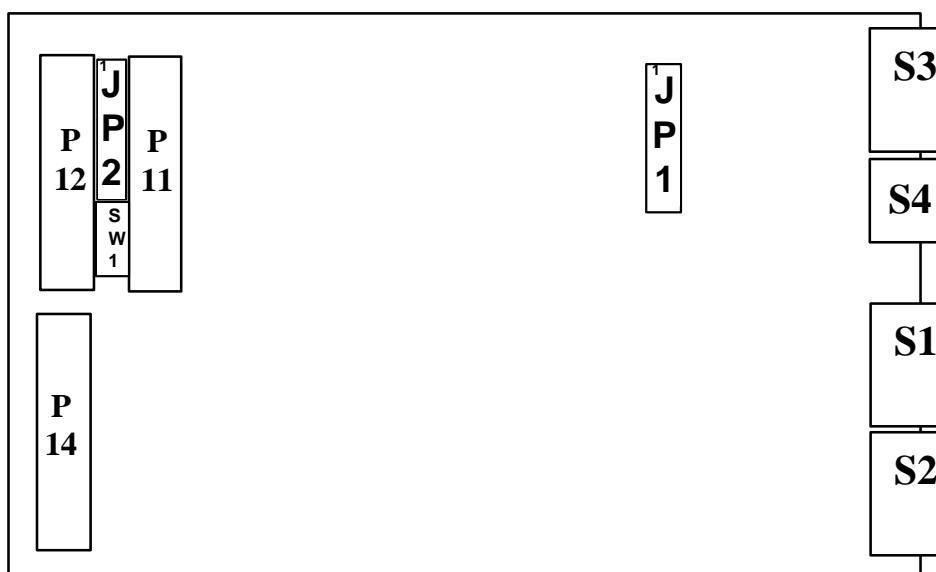

Please refer to the following tables to look up the pin assignment of the **NPMC-8280-4E1/T1/J1**.

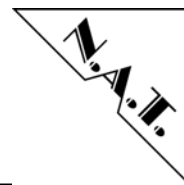

5.2 Connector JP1: BDM and JTAG connector

The RS232 serial I/O port is available via a 20 pin SMD micro connector together with the JTAG / development Port / BDM Port (see JP1 in the location overview).

The RS232 port is realised with the PowerQUICC serial communication controller SMC1.

Table 14: Development Port / BDM and IEEE 1149.1 Connector Pinout

		JTAG			
		BDM Port			
		PIN			
		JP1			
TDO	TDO	1	2	/QACK	
TDI	TDI	3	4	/TRST	/TRST
	/QREQ	5	6	+3.3V	
TCK	TCK	7	8	nc	
TMS	TMS	9	10	nc	
	/SRESET	11	12	GND	
	/HRESET	13	14	nc	
	/CHKSTOP_OUT	15	16	GND	
	RxD_SMC1	17	18	GND	
	TxD_SMC1	19	20	GND	

The BDM port (also called COP header) can be used for debugging. It is supported by major debug tool manufacturers.

Note: The BDM port is not assembled on normal production boards, as it is used only for debug purposes during kernel software development. If it is assembled, the connector JP1 slightly violates the height restrictions for PMC modules, which is 4.5mm at the location of JP1. If installed, JP1 is 5.5mm high.

An adapter board with cable plugging into the 20 pin SMD micro connector is available from N.A.T., that connects the JP1 connector to a standard 2-row, 16-pin, 100mil header used for BDM tool boxes, and routes the additional RS232 debug port signals to a standard 9-pin SubD female connector.

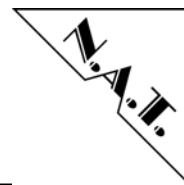

5.3 Connector JP2: Lattice programming port

Connector JP2 connects the JTAG- or programming-port of the Lattice CPLD devices. The CPLD devices are connected to a TDI – TDO daisy-chain.

Table 15: Lattice programming port

Pin No.	Signal	Signal	Pin No.
1	TCK	nc	2
3	TMS	GND	4
5	TDI	+3.3V	6
7	TDO	GND	8
9	/TRST	nc	10

5.4 DIL Switch SW1: FLASH Programming Enable Switch

During normal operation the FLASH may be (re)programmed any time by the MPC8280. Only in case the FLASH image has been corrupted the following programming procedure applies:

The FLASH programming mode is chosen by switching switch no. 1 of DIL switch SW1 to ON and powering up the module. This mode is to be used in order to program a completely empty or corrupted FLASH device. The MPC8280 will read the configuration word from a CPLD device and come up in Core Disabled Mode, and the FLASH will be visible in the window programmed in the MPC8280 from PCI to 60x bus. After having programmed the FLASH, the switch has to be set to OFF again and power needs to be cycled for the CPU to come out of Power-On-Reset with core enabled. Sample code is available on request.

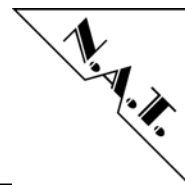

5.5 PMC Connector P11

Table 16: PMC Connector P11

Pin No.	PCI-Signal	PCI-Signal	Pin No.
1	TCK	-12V	2
3	GND	/INT A	4
5	/INT B	/INT C	6
7	/BUSMODE1	+5V	8
9	/INT D	PCI_RSV1	10
11	GND	3.3Vaux	12
13	CLK	GND	14
15	GND	/GNT	16
17	/REQ	+5V	18
19	V (I/O)	AD31	20
21	AD28	AD22	22
23	AD25	GND	24
25	GND	CBE3	26
27	AD22	AD21	28
29	AD19	+5V	30
31	V (I/O)	AD17	32
33	/FRAME	GND	34
35	GND	/IRDY	36
37	/DEVSEL	+5V	38
39	GND	/LOCK	40
41	/SDONE	/SBO	42
43	PAR	GND	44
45	V (I/O)	AD15	46
47	AD12	AD11	48
49	AD09	+5V	50
51	GND	/CBE0	52
53	AD06	AD05	54
55	AD04	GND	56
57	V (I/O)	AD03	58
59	AD02	AD01	60
61	AD00	+5V	62
63	GND	/REQ64	64

Pins for –12V, Vaux, and V(I/O) are not connected to the module. The same applies to JTAG signal TCK and PCI signals /LOCK, /SDONE, /SBO, /INTB, /INTC, /INTD. The PCI bridge chip always drives signals to 3.3V level, but it 5V tolerant.

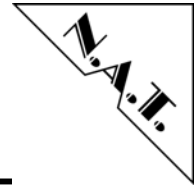

5.6 PMC Connector P12

Table 17: PMC Connector P12

Pin No.	PCI-Signal	PCI-Signal	Pin No.
1	+12V	/TRST	2
3	TMS	TDO	4
5	TDI	GND	6
7	GND	PCI_RSV3	8
9	PCI_RSV	PCI_RSV4	10
11	/BUSMODE2	+3.3V	12
13	/PCIRST	/BUSMODE3	14
15	+3.3V	/BUSMODE4	16
17	/PME	GND	18
19	AD30	AD29	20
21	GND	AD26	22
23	AD24	+3.3V	24
25	IDSEL	AD23	26
27	+3.3V	AD20	28
29	AD18	GND	30
31	AD16	/CBE2	32
33	GND	PCI_RESVD	34
35	/TRDY	+3.3V	36
37	GND	/STOP	38
39	/PERR	GND	40
41	+3.3V	/SERR	42
43	/CBE1	GND	44
45	AD14	AD13	46
47	M66EN	AD10	48
49	AD08	+3.3V	50
51	AD07	PCI_RESV	52
53	+3.3V	PCI_RESV	54
55	PCI_RESV	GND	56
57	PCI_RESV	PCI_RESV	58
59	GND	PCI_RESV	60
61	ACK64	+3.3V	62
63	GND	PCI_RESV	64

Pins for +12V and /BUSMODE2 are not connected to the module. The same applies to JTAG signals TMS and /TRST. JTAG TDI is connected to TDO.

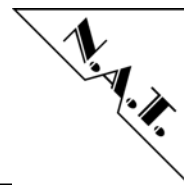

5.7 PMC Connector P14 (PMC I/O)

Table 18: PMC Connector P14

ext. Signal	Pin No.	PCI-Signal	PCI-Signal	Pin No.	ext. Signal
MC	1	I/O	I/O	2	CT_D15
CT_D14	3	I/O	I/O	4	CT_D13
CT_D12	5	I/O	I/O	6	GND
CT_D11	7	I/O	I/O	8	CT_D10
CT_D09	9	I/O	I/O	10	CT_D8
CT_D07	11	I/O	I/O	12	GND
CT_D06	13	I/O	I/O	14	CT_D5
CT_D04	15	I/O	I/O	16	CT_D3
CT_D02	17	I/O	I/O	18	CT_D1
GND	19	I/O	I/O	20	CT_D0
CLKFAIL	21	I/O	I/O	22	/FSYNC
SREF_8K	23	I/O	I/O	24	SCLK
GND	25	I/O	I/O	26	/SCLKx2
SL_4	27	I/O	I/O	28	/C16+
SL_2	29	I/O	I/O	30	SL_3
SL_0	31	I/O	I/O	32	SL_1
SPICK	33	I/O	I/O	34	/SPISEL
SPIMISO	35	I/O	I/O	36	SPIMOSI
/C16-	37	I/O	I/O	38	CT_FRAME_B
CT_FRAME_A	39	I/O	I/O	40	CT_NETREF2
CT_NETREF1	41	I/O	I/O	42	/C4
C2	43	I/O	I/O	44	GND
CT_C8_B	45	I/O	I/O	46	CT_C8_A
CT_D16	47	I/O	I/O	48	CT_D17
CT_D18	49	I/O	I/O	50	CT_D19
GND	51	I/O	I/O	52	CT_D20
CT_D21	53	I/O	I/O	54	CT_D22
CT_D23	55	I/O	I/O	56	CT_D24
GND	57	I/O	I/O	58	CT_D25
CT_D26	59	I/O	I/O	60	CT_D27
CT_D28	61	I/O	I/O	62	CT_D29
CT_D30	63	I/O	I/O	64	CT_D31

The SCbus implemented on the **NPMC-8280-E1/T1/J1** is a sub-set of the H.110 bus. SCbus data lines correspond to H.110 data lines CT_D0 – 15.

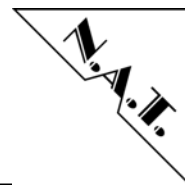

5.8 The Front Panel Connectors (S1 – S4)

The front panel connectors are 8-pin RJ45 connectors. The 4 E1/T1/J1 line interfaces are available on the pins of the front panel connectors S1 and S2. Tables 19 - 20 show the pin assignments.

Table 19: Pin Assignment of the Front-panel Connectors S1 (ISDN)

Pin No.	Signal	Signal	Pin No.
1	TX3+	TX3-	2
3	TX1+	RX1+	4
5	RX1-	TX1-	6
7	RX3+	RX3-	8

Table 20: Pin Assignment of the Front-panel Connectors S2 (ISDN)

Pin No.	Signal	Signal	Pin No.
1	TX4+	TX4-	2
3	TX2+	RX2+	4
5	RX2-	TX2-	6
7	RX4+	RX4-	8

Table 21 shows the pin assignment of RJ45-connector S3. This connector carries the 100BaseT signals of the Ethernet interface. Term. is the 100BaseT termination used for pins 4, 5, 7, and 8.

Table 21: Pin Assignment of the Front-panel Connectors S3 (Ethernet)

Pin No.	Signal	Signal	Pin No.
1	TX+	TX-	2
3	RX+	Term.	4
5	Term.	RX-	6
7	Term.	Term.	8

Table 22 shows the pin assignment of the signals of the RS232 interface

Table 22: Pin Assignment of the Front-panel Connectors S4 (RS232)

Pin No.	Signal	Signal	Pin No.
1	not used	RxD_SCC1	2
3	TxD_SCC1	not used	4
5	GND		

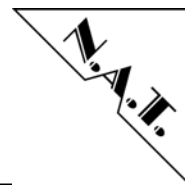

6 NPMC-8280-4E1/T1/J1 Programming Notes

6.1 CPU - PLL-Setup

The basic setting of the clocks is done by pulling the MODCK pins during /PORESET. These are programmable through CPLD U13 (BA0-2). There are 5 additional pins (PCIMODCKx) responsible for setting the PLLs, which are also read during /PORESET. The chosen PLL setting is MODCK1 - 3 = 100b and PMODCKH0 - 3 = 0100b for a 300/200 MHz CPU/CPM version. Whether the PCI clock frequency is 33 MHz or 66 MHz, depends on the status of the PMC /M66EN signal during /HRESET.

6.2 Hard Reset Configuration Word

6.2.1 Core Enabled Mode (default)

/RSTCONF is tied to GND, therefore the MPC8280 is the configuration master, i.e. it reads configuration data during the /HRESET - phase from a CPLD. In case an empty FLASH shall be programmed via the PCI bus, the MPC8280 can be put into Core Disabled mode by switching switch no. 1 of DIL switch SW1 to ON. This special setting provides special configuration data through a CPLD. The configuration data used for normal power-up (not FLASH programming mode) read as follows:

Table 23: Hard Reset Configuration Word (as read from CPLD)

Bit	Name	Value	Description
0	EARB	0b	internal arbiter active
1	EXMC	0b	internal Memory-Controller
2	CDIS	0b	Core enabled
3	EBM	1b	601 compatible bus mode
4-5	BPS	10b	Boot Port Size 16 bit
6	CIP	1b	Position of the Vector Table is 0H
7	ISPS	0b	64-bit slave
8-9	L2CPC	10b	L2 Cache pins defined as BADDRx
10-11	DPPC	0b	Data Parity Pins used as IRQ pins
12	rsvd	0b	clear
13-15	ISB	010b	initial internal space base select is 0x0F00.0000
16	BMS	1b	boot from low mem
17	BBD	0b	ABB, DBB Pins defined
18-19	MMR	0b	no external master requests masked
20-21	LBPC	01b	PCI bus pins enabled
22-23	APPC	10b	Bank Select function selected
24-25	CS10PC	01b	BCTL1 selected
26	ALD_EN	0b	autoload disabled
27	rsvd	0b	clear
28-31	MODCK_H	0b	PLL config., clear (not valid for PCI mode)

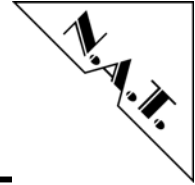

6.2.2 Core Disabled Mode (FLASH programming mode)

In case of FLASH programming mode the ALD_EN bit in the Hard Reset Configuration Word is set to 1b (autoload function, bit 26). In this case, the MPC8280 reads additional information from the CPLD, in order to do some basic register setup. The start address of this block of additional information is always read from address 0x04. The CPLD sets the block start address to be 0x80. The following register setup is performed in core disabled mode for FLASH programming mode:

- SYPCR is written 0xFFFF.FF00 in order to disable the watchdog
- PCI Sub System Device ID is written 0x0415, which is used as N.A.T. board identification code
- PCI Bus Function register is written 0x0 in order to clear CFG_LOCK and enable PCI access to the bridge
- register OR0 is written 0xFE00.0E84, which reduces the no. of waitstates to 8
- register BR0 is written 0xFE00.1001, which sets the port size to 16 bits data width

With these settings FLASH programming via the PCI bus can be performed with the CPU core in disabled mode. After the FLASH programming is completed, switch no. 1 of DIL switch SW1 has to be set to position 'OFF' again, in order to allow core enabled boot with the next power-on.

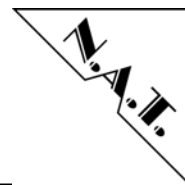

6.3 Recommended General Control Register Setup

6.3.1 Register-Setup of the System Clock Control Register (SCCR)

SCCR Bit	Name	Value	Description
Bit 0-28	rsvd	0b	clear
Bit 29	CLPD	0b	CPM does not enter low power mode
Bit 30-31	DFBRG	0b	division factor of 4

6.3.2 Register-Setup of the System Protection Control Register (SYPCR)

SYPCR Bit	Name	Value	Description
Bit 0-15	SWTC	0xFFFF	software watchdog timer count
Bit 16-23	BMT	0xFF	bus monitor timing
Bit 24	PBME	1b	60x bus monitor enabled
Bit 25	LBME	1b	local bus monitor enabled
Bit 26-28	rsvd	0b	clear
Bit 29	SWE	0b	software watchdog disabled
Bit 30	SWRI	1b	watchdog and bus monitors cause soft reset
Bit 31	SWP	1b	software watchdog timer is prescaled

6.3.3 Register-Setup of the Bus Configurations Register (BCR)

BCR Bit	Name	Value	Description
Bit 0	EBM	1b	external bus mode 60x mode
Bit 1-3	APD	100b	address phase delay
Bit 4	L2C	0b	no secondary cache
Bit 5-7	L2D	0b	hit delay, not applicable
Bit 8	PLDP	1b	pipeline max. depth
Bit 9-10	rsvd	0b	clear
Bit 11	EAV	1b	full address on 60x bus
Bit 12	ETM	0b	compatibility mode enable, disabled
Bit 13	LETM	0b	local compatibility mode enable, disabled
Bit 14	EPAR	0b	even parity
Bit 15	LEPAR	0b	local even parity
Bit 16-18	NPQM	111b	non PowerQUICC master
Bit 19-20	rsvd	0b	clear
Bit 21	EXDD	0b	external master delay enabled
Bit 22-26	rsvd	0b	clear
Bit 27	ISPS	0b	internal space port size is 64 bit
Bit 28-31	rsvd	0b	clear

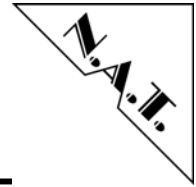

6.3.4 Register-Setup of the 60x Bus Arbiter Configurations Register (PPC_ACR)

P_ACR Bit	Name	Value	Description
Bit 0-1	rsvd	0b	clear
Bit 2	DBGD	0b	DBG asserted with TS
Bit 3	EARB	0b	internal bus arbitration
Bit 4-7	PRKM	0010b	parking master is CPM low request level

6.3.5 Register-Setup of the Local Bus Arbiter Configurations Register (LCL_ACR)

L_ACR Bit	Name	Value	Description
Bit 0	rsvd	0b	clear
Bit 2	DBGD	0b	DBG asserted with TS
Bit 3	EARB	0b	internal bus arbitration
Bit 4-7	PRKM	0110b	parking master is internal core

6.3.6 Register-Setup of the SIU Module Configurations Register (SIUMCR)

SIUMCR Bit	Name	Value	Description
Bit 0	BBD	0b	ABB, DBB selected
Bit 1	ESE	0b	IRQ1 selected
Bit 2	PBSE	0b	parity byte select disabled
Bit 3	CDIS	0b	core enabled
Bit 4-5	DPPC	00b	IRQ function selected
Bit 6-7	L2CPC	10b	BADDRx selected
Bit 8-9	LBPC	1b	PCI bus pins selected
Bit 10-11	APPC	10b	BNKSEL function enabled
Bit 12-13	CS10PC	01b	BCTL1 selected
Bit 14-15	BCTLC	0b	buffer control
Bit 16-17	MMR	0b	no masking of bus requests
Bit 18	LPBSE	0b	local parity disabled
Bit 19-31	rsvd	0b	clear

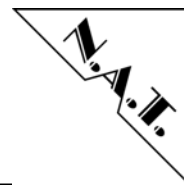

6.3.7 Register-Setup of the 60x Bus Transfer Status/Control Register (TESCR1)

SCCR Bit	Name	Value	Description
Bit 0-16	not used	0b	clear
Bit 17	DMD	1b	all data errors disabled
Bit 18-31	not used	0b	clear

6.3.8 Register-Setup of the Local Bus Transfer Status/Control Register (L_TESCR1)

SCCR Bit	Name	Value	Description
Bit 0-16	not used	0b	clear
Bit 17	DMD	1b	all data parity errors disabled
Bit 18-31	not used	0b	clear

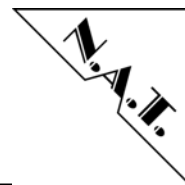

6.4 Recommended Register Setup of the Memory Controller:

6.4.1 Base Registers BRx:

The base addresses given in the description below are the ones chosen for the OK1 and VxWorks implementations for the NPMC-8280-E1/T1/J1. They may be altered to suit the user's needs.

BRx: Base Register of the corresponding CS; CS settings as described in Table 3 above.

BR0 Bit	Name	Value	Description
Bit 0-16	BA	<address>	base address <address>, FLASH
Bit 17-18	rsvd	0b	clear
Bit 19-20	PS	10b	port size 16 bit
Bit 21-22	DECC	0b	ECC disabled
Bit 23	WP	0b	R/W
Bit 24-26	MS	0b	default, 601 bus
Bit 27	EMEMC	0b	memory controller active
Bit 28-29	ATOM	0b	no atomic operations
Bit 30	DR	0b	no data pipelining
Bit 31	V	1b	valid bank

BR1 not used.

BR2 Bit	Name	Value	Description
Bit 0-16	BA	<address>	base address <address>, SDRAM CS0
Bit 17-18	rsvd	0b	clear
Bit 19-20	PS	0b	port size 64 bit
Bit 21-22	DECC	0b	ECC disabled
Bit 23	WP	0b	R/W
Bit 24-26	MS	010b	SDRAM, 601 bus
Bit 27	EMEMC	0b	memory controller active
Bit 28-29	ATOM	0b	no atomic operations
Bit 30	DR	0b	no data pipelining
Bit 31	V	1b	valid bank

The settings of BR2 and BR3 are suitable for the default 32 MB SODIMM module installed. The default module uses only one CS, hence the programming of BR3/OR3 is not necessary.

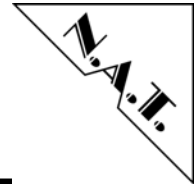

BR3 Bit	Name	Value	Description
Bit 0-16	BA	<address>	base address <address>, SDRAM CS1
Bit 17-18	rsvd	0b	clear
Bit 19-20	PS	0b	port size 64 bit
Bit 21-22	DECC	0b	ECC disabled
Bit 23	WP	0b	R/W
Bit 24-26	MS	010b	SDRAM, 601 bus
Bit 27	EMEMC	0b	memory controller active
Bit 28-29	ATOM	0b	no atomic operations
Bit 30	DR	0b	no data pipelining
Bit 31	V	0b	invalid bank

BR4 Bit	Name	Value	Description
Bit 0-16	BA	<address>	base address <address>, Reset register
Bit 17-18	rsvd	0b	clear
Bit 19-20	PS	01b	port size 8 bit
Bit 21-22	DECC	0b	ECC disabled
Bit 23	WP	0b	R/W
Bit 24-26	MS	0b	GPCM, 601 bus
Bit 27	EMEMC	0b	memory controller active
Bit 28-29	ATOM	0b	no atomic operations
Bit 30	DR	0b	no data pipelining
Bit 31	V	1b	valid bank

BR5 Bit	Name	Value	Description
Bit 0-16	BA	<address>	base address <address>, TSI
Bit 17-18	rsvd	0b	clear
Bit 19-20	PS	01b	port size 8 bit
Bit 21-22	DECC	0b	ECC disabled
Bit 23	WP	0b	R/W
Bit 24-26	MS	0b	GPCM, 601 bus
Bit 27	EMEMC	0b	memory controller active
Bit 28-29	ATOM	0b	no atomic operations
Bit 30	DR	0b	no data pipelining
Bit 31	V	1b	valid bank

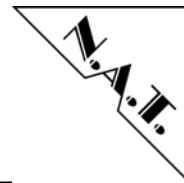

BR6 Bit	Name	Value	Description
Bit 0-16	BA	<address>	base address <address>, QuadFALC
Bit 17-18	rsvd	0b	clear
Bit 19-20	PS	01b	port size 8 bit
Bit 21-22	DECC	0b	ECC disabled
Bit 23	WP	0b	R/W
Bit 24-26	MS	0b	GPCM, 601 bus
Bit 27	EMEMC	0b	memory controller active
Bit 28-29	ATOM	0b	no atomic operations
Bit 30	DR	0b	no data pipelining
Bit 31	V	1b	valid bank

BR7 - 11 not used.

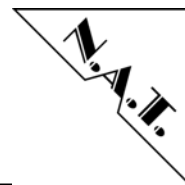

6.4.2 Option Registers ORx

The address masks given in the description below are the ones chosen for the OK1 and VxWorks implementations for the NPMC-8280-E1. They may be altered to suit the user's needs.

ORx: Option Registers of the corresponding CS, CS settings as described in Table 3 above.

OR0 Bit	Name	Value	Description
Bit 0-16	AM	FF00.0H	address mask, size of the CS range, 16 MB
Bit 17-18	rsvd	0b	clear
Bit 19	BCTLD	0b	BCTLx enabled (R/W control)
Bit 20	CSNT	1b	CS/WE timing parameter
Bit 21-22	ACS	11b	CS timing parameter
Bit 23	rsvd	0b	clear
Bit 24-27	SCY	1011b	11 WS = 13 clock cycles = 170ns access time
Bit 28	SETA	0b	internal TA/PSDVAL generation
Bit 29	TRLX	0b	normal timing
Bit 30	EHTR	0b	normal timing
Bit 31	rsvd	0b	clear

OR1 not used.

OR2 Bit	Name	Value	Description
Bit 0-11	SDAM	FE0H	SDRAM address mask, size of the CS range, 32 MB
Bit 12-16	LSDAM	0H	lower SDRAM address mask
Bit 17-18	BPD	01b	banks per device, default: 4 banks
Bit 19-21	ROWST	0010b	row start address bit (from SDRAM EEPROM), see also DRTYPEx programming
Bit 22	rsvd	0b	clear
Bit 23-25	NUMR	011b	number of row address lines (from SDRAM EEPROM)
Bit 26	PMSEL	0b	page mode select back to back
Bit 27	IBID	0b	internal bank interleave activated
Bit 28-31	rsvd	0b	clear

The settings of OR2 and OR3 are suitable for the default 32 MB SODIMM module installed. The default module uses only one CS, hence the programming of BR3/OR3 is not necessary.

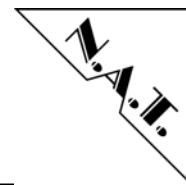

OR3 Bit	Name	Value	Description
Bit 0-11	SDAM	FE0H	SDRAM address mask, size of the CS range, 32 MB
Bit 12-16	LSDAM	0H	lower SDRAM address mask
Bit 17-18	BPD	01b	banks per device, default: 4 banks
Bit 19-21	ROWST	0010b	row start address bit (from SDRAM EEPROM), see also DRTYPEx programming
Bit 22	rsvd	0b	clear
Bit 23-25	NUMR	011	number of row address lines (from SDRAM EEPROM)
Bit 26	PMSEL	0b	page mode select back to back
Bit 27	IBID	0b	internal bank interleave activated
Bit 28-31	rsvd	0b	clear

OR4 Bit	Name	Value	Description
Bit 0-16	AM	FFFF.0H	address mask, size of the CS range, 64 KB
Bit 17-18	rsvd	0b	clear
Bit 19	BCTLD	0b	L_WR enabled (R/W control)
Bit 20	CSNT	0b	CS/WE timing parameter
Bit 21-22	ACS	11b	CS timing parameter
Bit 23	rsvd	0b	clear
Bit 24-27	SCY	0101b	5 WS = 7 clock cycles = 80ns access time
Bit 28	SETA	0b	internal TA/PSDVAL generation
Bit 29	TRLX	1b	relaxed timing, doubles access time to 160ns
Bit 30	EHTR	1b	extended hold time
Bit 31	rsvd	0b	clear

OR5 Bit	Name	Value	Description
Bit 0-16	AM	FFFF.0H	address mask, size of the CS range, 64 KB
Bit 17-18	rsvd	0b	clear
Bit 19	BCTLD	0b	L_WR enabled (R/W control)
Bit 20	CSNT	0b	CS/WE timing parameter
Bit 21-22	ACS	11b	CS timing parameter
Bit 23	rsvd	0b	clear
Bit 24-27	SCY	0101b	5 WS = 7 clock cycles = 80ns access time
Bit 28	SETA	0b	internal TA/PSDVAL generation
Bit 29	TRLX	1b	relaxed timing, doubles access time to 160ns
Bit 30	EHTR	1b	extended hold time
Bit 31	rsvd	0b	clear

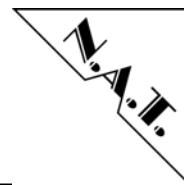

OR6 Bit	Name	Value	Description
Bit 0-16	AM	FFFF.0H	address mask, size of the CS range, 64 KB
Bit 17-18	rsvd	0b	clear
Bit 19	BCTLD	0b	L_WR enabled (R/W control)
Bit 20	CSNT	0b	CS/WE timing parameter
Bit 21-22	ACS	11b	CS timing parameter
Bit 23	rsvd	0b	clear
Bit 24-27	SCY	0101b	5 WS = 7 clock cycles = 80ns access time
Bit 28	SETA	0b	internal TA/PSDVAL generation
Bit 29	TRLX	1b	relaxed timing, doubles access time to 160ns
Bit 30	EHTR	1b	extended hold time
Bit 31	rsvd	0b	clear

OR7 - 11 not used.

6.4.3 Configuration for SDRAM Register Setup

The correlation between address lines to be multiplexed and the programming of the signals DRTYPE_x and Bank Select (BA_x) is as follows:

DRTYPE_x settings are related to the SODIMM SDRAM row/column organisation. The following table shows which is the highest column address to be multiplexed, which address lines have to be put out by the BA_x lines (BA₀ is not connected), and how SDA₁₀ should be programmed according to the setting of DRTYPE_x:

DRTYPE ₁	DRTYPE ₀	highest col. addr. to be muxed	BA ₁	BA ₂	SDA ₁₀
0	0	SDA ₇	PB_A ₁₉	PB_A ₂₀	PB_A ₈
0	1	SDA ₈	PB_A ₁₈	PB_A ₁₉	PB_A ₇
1	0	SDA ₉	PB_A ₁₇	PB_A ₁₈	PB_A ₆
1	1	SDA ₁₁	PB_A ₁₆	PB_A ₁₇	PB_A ₅

DRTYPE_x are programmable by Port pins of the MPC8280. DRTYPE₀ is PD₂₃, DRTYPE₁ is PD₂₂.

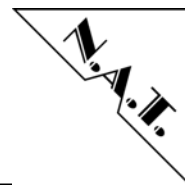

6.4.4 SDRAM Mode Register PSDMRx

PSDMR Bit	Name	Value	Description
Bit 0	PBI	1b	page-based Interleave
Bit 1	RFEN	1b	refresh necessary
Bit 2-4	OP	000b	SDRAM operation
Bit 5-7	SDAM	010b	depending on SDRAM parameters and on DRTYPE _x
Bit 8-10	BSMA	110b	depending on SDRAM parameters and on DRTYPE _x
Bit 11-13	SDA10	010b	depending on SDRAM parameters and on DRTYPE _x (see table below)
Bit 14-16	RFRC	110b	depending on SDRAM parameters
Bit 17-19	PRETOACT	100b	depending on SDRAM parameters
Bit 20-22	ACTTORW	100b	depending on SDRAM parameters
Bit 23	BL	0b	burst length is 4
Bit 24-25	LDOTOPRE	10b	depending on SDRAM parameters
Bit 26-27	WRC	11b	depending on SDRAM parameters
Bit 28	EAMUX	1b	external address multiplexer
Bit 29	BUFCMD	0b	normal timing
Bit 30-31	CL	10b	depending on SDRAM parameters

6.4.5 PSRT 60x Bus-Assigned SDRAM Refresh Timer Register

PSRT Bit	Name	Value	Description
Bit 0-7	PSRT	20H	timer value of 32 for prescaler 64

6.4.6 MPTPR Memory Refresh Timer Prescaler Register

MPTPR Bit	Name	Value	Description
Bit 0-7	PSRT	40H	prescaler value 64
Bit 8-15	rsvd	0b	clear

6.4.7 UPM Machine Mode Register MxMR

UPMs are not used in this version. If UPMs are to be used, take the restriction of bus frequency and UPM usage for some MPC826x masks and versions into account.

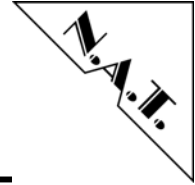

6.5 Setup of the Serial Interfaces

6.5.1 RS232 Interface on the Front Panel Connector S4

The programming of the RS232 serial interface is performed through SCC1 (PD30, PD31).

6.5.2 RS232 Debug Interface

The programming of the RS232 serial debug interface is performed through SMC1 (PD8, PD9).

6.5.3 I²C Interface

The I²C interface is connected to port pins PD14 (Clk) and PD15 (Data). The EEPROM on the SDRAM SODIMM module has address 0 and should be read and analyzed before initialising the SDRAM machine, in order to be able to setup the SDRAM machine, the external logik (DRTYPE_x for U13), and the SDRAMs themselves. The address of the EEPROM U10 used for storage of board-specific parameters is 4. The control code (1st 4 bits of the address) for the 24Cxx EEPROM is 1010b, which results in address \$50 for the SODIMM EEPROM and in address \$54 for the parameter EEPROM.

6.5.4 SPI Interface

The SPI interface is connected to port pins PD16 (SPIMISO), PD17 (SPIMOSI), PD18 (SPICLK), and PD19 (/SPISEL). It is accessible on the PMC I/O connector P14. No onboard devices are connected to the SPI interface.

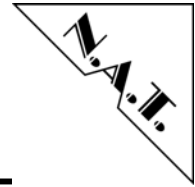

6.6 Definition of the Multi-Function Pins

Table 24: Definition of the Multi-Function Pins

Pin Name	Pin Function on the NPMC-8280-4E1/T1/J1
DBB/IRQ3	DBB
DP(0-7)/misc.	IRQx
GBL/IRQ1	GBL, not used
CI/BADDR29/IRQ2	BADDR29
WT/BADDR30/IRQ3	BADDR30
L2_HIT/IRQ4	L2_HIT, not used
CPU_BG/BADDR31/IRQ5	BADDR31
CS10/BCTL1/DBG_DIS	BCTL1
CS11/AP0	NC
PWE(0-7)/PSDDQM(0-7)/PBS(0-7)	PSDDQM(0-7)
PSDA10/PGPL0	PSDA10
PSDWE/PGPL1	PSDWE
POE/PSDRAS/PGPL2	PSDRAS
PSDCAS/PGPL3	PSDCAS
PGTA/PUPMWAIT/PGPL4/PPBS	PGTA
PSDAMUX/PGPL5	PSDAMUX
IRQ0/NMIOUT	IRQ0
IRQ7/INTOUT/APE	INTOUT, not used
MODCKx/Ap _x /TC _x /BNKSEL _x	BNKSEL _x

7 Known Bugs / Restrictions

none

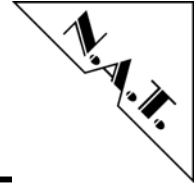

8 Differences between Hardware Revisions 1.4 and 2.0

The Manual describes the features of the **NPMC-8280-4E1/T1/J1** Hardware Revision 2.0. As there are some differences between Hardware Revisions 1.4 and 2.0, this chapter was added to describe the different functionality of HW Rev. 1.4. Only those chapters are listed, where there are differences to be taken into account. All other chapters not listed here are valid for both Hardware Revisions 1.4 and 2.0.

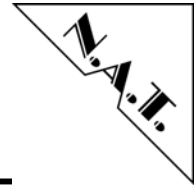

8.1 H.110 Bus Controller and Line Interfaces

8.1.1 Block Diagramm of the TDM Structure

Figure 8: Local TDM Bus Organisation and Synchronisation

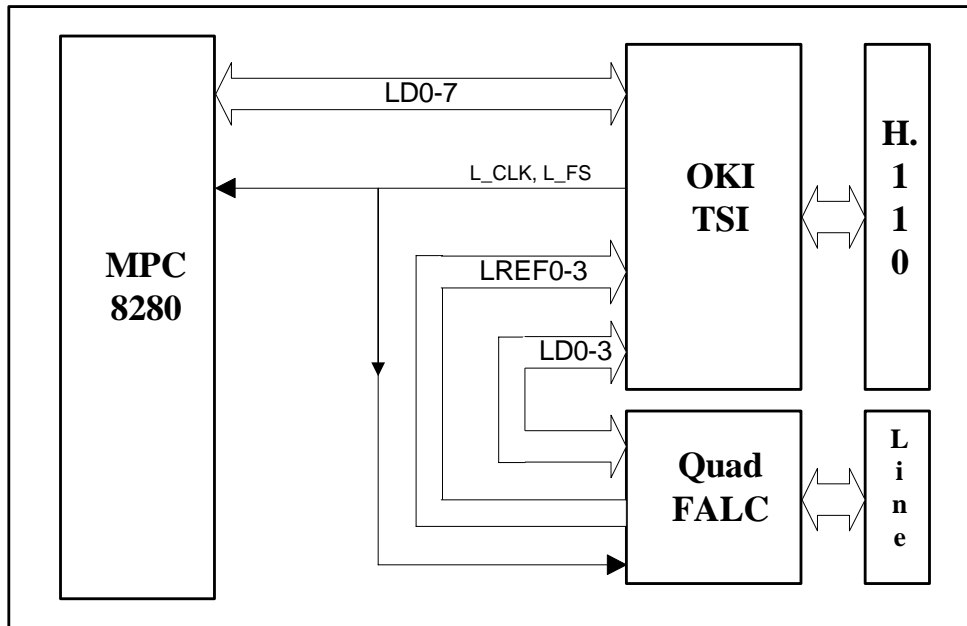

8.1.2 Description of the TDM Structure

The TDM data are routed through the ML53812-2 TSI device. Hence, any timeslot switching between H.110 bus, framers, and CPU is possible. Local TDM data lines LD0 – 3 are routed between QuadFALC and TSI and CPU. In order to prevent data distortion the data outputs of the QuadFALC may be isolated from the TDM bus, if all 8 TDM lines are to be used between TSI and CPU. The switch element connecting the QuadFALC data lines LD0 – 3 is enabled by programming CPU port pin PA0. Default: QuadFALC data lines LD0 – 3 enabled.

The TSI device derives its time base from one of the LREF signals coming from the framers, or from the H.110 bus. From this input it generates local clock and frame sync for the framers and the CPU to synchronize to. Timing reference for offboard routing devices can be provided by programming one of the local LREF signals to be output on one of the NETREFx signals. For detailed information please refer to the Motorola MPC8280, OKI ML53812-2, and Infineon PEB22554 User's Manuals.

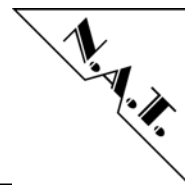

8.2 Definition of PowerQUICC II Port Pins

PowerQUICC II port pins are used to communicate with the framers and to set up some board configuration. In detail:

Table 25: PowerQUICC II Port Pin Usage (Port A)

Signal Function	PowerQUICC II Port A Pin	Description
...
NC	PA1	not used
LDO_F_EN*	PA0	enable TDM data lines between QuadFALC and CPU

Table 26: PowerQUICC II Port Pin Usage (Port C)

Signal Function	PowerQUICC II Port C Pin	Description
...
IMPSELA*	PC9	E1/T1/J1 Receive Interface Impedance Select
IMPSELB*	PC8	E1/T1/J1 Receive Interface Impedance Select
IMPSELC*	PC7	E1/T1/J1 Transmit Interface Impedance Select
...

Signals with asterisk (*) are described in detail below.

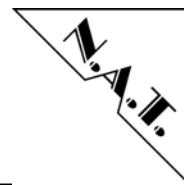

8.2.1 Signal Description

Port pins without signal name and description are not connected and should be programmed as outputs.

8.2.1.1 Selecting the TDM Data Path for LD0 - 3

LDO_F_EN enables TDM data lines 0 – 3 between QuadFALC and CPU
 LDO_F_EN = 1: TDM data lines 0 – 3 between QuadFALC and CPU are enabled, TDM data lines 4 – 7 may be used between CPU and OKI TSI (*default*)
 LDO_F_EN = 0: TDM data lines 0 – 3 between QuadFALC and CPU are disabled, TDM data lines 0 – 7 may be used between CPU and OKI TSI

Note: This feature is available only from HW release 1.2 up. Earlier versions have TDM data lines 0 – 3 hard-wired between QuadFALC and CPU, and TDM data lines 4 – 7 hard-wired between CPU and OKI TSI.

8.2.1.2 Selecting the ISDN Line Impedance

IMPSELA, IMPSELB Line impedance select lines used for selection of 100 Ω (T1), 110 Ω (J1), 120 Ω (E1), or 75 Ω (E1) receiver line termination

IMPSELA	IMPSELB	receiver line termination
0	0	100 Ω (T1)
0	1	75 Ω (E1)
1	0	120 Ω (E1) (<i>default</i>)
1	1	110 Ω (J1)

IMPSELC transmitter line termination

IMPSELC	transmitter line termination
0	2 Ω (T1/J1) (<i>default</i>)
1	7.5 Ω (E1)

The FET switches used for hardware selection of transmitter line termination are not assembled by default; transmitter line termination is performed by software. In case transmitter line termination by hardware is requested, contact N.A.T. for this assembly option. For both ways of transmitter line termination different driver software is needed.

Default: programming of IMPSELC has no effect

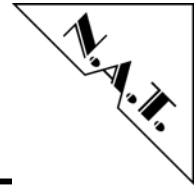

8.3 Register

8.3.1 Lattice Revision Register

There is an 8 bit wide Lattice CPLD revision register implemented in the CPLD onboard the **NPMC-8280-4E1/T1/J1**, which contains the revision code of the Lattice CPLD. This code reads decimally-coded in 2 nibbles, i.e. the CPLD version V1.0 reads 0x10. The register is addressed by the Register Chip Select CS4 as described in Table 5: with address offset 0x8.

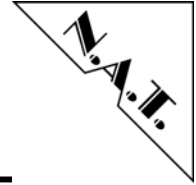

Appendix A: Reference Documentation

- [1] Motorola Inc., MPC8280 PowerQUICC II Family Reference Manual, 3/2004, Rev. 0
- [2] OKI Inc., ML53812-2 Universal Timeslot Interchange, Preliminary Data Sheet, 1996, Rev. 1.3
- [3] Infineon, PEB22554 E1/T1/J1 Framer / Transceiver, DS1, 7/2000
- [4] Infineon, PEF22554 E1/T1/J1 Framer / Transceiver, DS1, 9/2002
- [5] Level One, LXT972A 3.3V Dual-Speed Fast Ethernet Transceiver, 9/2000, Rev. 1.0
- [6] N.A.T. GmbH, NFAPI Manual, 1999, Rev.1.7

